

Operating and technical instructions



CE
2460

Heka G⁺

KEEP THIS MANUAL WITH THE DENTAL DELIVERY SYSTEM AT ALL TIMES
Manuals for OEM equipment are included in the shipping boxes.
Installation, Service, and Maintenance by authorized Heka Dental dealers only



Table of Contents

Introduction	9
Description	10
Intended Purpose.....	10
Indications for use	10
Contraindications.....	10
Warnings and precautions	11
Cautions	13
Additional Safety Information.....	14
Use of instruments.....	14
Regulatory classification	14
Symbols.....	15
Symbols on packaging material.....	17
Transport and stock conditions	17
Heka G+ overview.....	18
Components	19
Special equipment and instruments	19
Accessories.....	19
Starting up the Heka G+.....	20
Multi-dentist and multi-treatment.....	20
When a dentist has been set up	20
In case multiple dentists are setup.....	20
Online user registration for dentists	20
Register as a user of a Heka unit	20
Heka ID.....	21
Foot controls.....	22
Standard wireless foot control.....	23
Standard variable wireless foot control.....	24
Universal variable foot control	25

Instrument table display	26
Description of the instrument table touch keys	28
Description of the console top keys	28
Turbine instrument.....	29
Available settings	29
Factory settings.....	29
Turbine instrument display	30
Operation.....	30
Changing the spray function	30
Water and air adjustments	30
Motor instrument.....	31
Available settings	31
Factory settings.....	32
Motor instrument display.....	32
Operation.....	32
Manual adjustment of the motor speed.....	32
Torque.....	33
Direction of rotation.....	33
Changing the spray combinations.....	33
Water and air adjustment	34
Ultrasonic scaler	35
Available settings	35
Factory settings.....	35
Ultrasonic scaler display	36
Operation.....	36
Changing the spray function	36
Water adjustment.....	37
Air ultrasonic scaler	38
Available settings	38
Factory settings.....	38
Air display, Ultrasonic scaler	39
Operation.....	39
Changing the spray function	39
Water adjustment.....	39
Light polymerisation instrument.....	40
Available settings	40
Factory settings.....	41
Light polymerisation instrument display	41
Operation.....	41

Manual adjustment of the curing light time	41
Syringe instrument.....	42
Available settings	42
Factory settings.....	42
Operation.....	42
Water and air adjustment	42
Intraoral camera instrument.....	43
Available settings	43
Factory settings.....	43
Intraoral camera instrument display	43
Operation.....	43
For Acteon Sopro cameras.....	43
Air Polisher instrument.....	44
Available settings	44
Factory settings.....	44
Air Polisher instrument display	44
Preparing for the treatment/refilling the powder container	44
Operation.....	45
Water and air adjustment	45
Sterile water system	46
Available settings	46
Installation of sterile water system	46
Operation.....	46
Sterile water system activation	47
Normal water supply	47
Water bottle systems	47
Options.....	47
Operation.....	47
Water treatment system.....	48
Options	48
Function	48
Operation and Warnings	48
Cleaning	49
Timer.....	50
Available settings	50
Factory settings.....	50
Timer display.....	50

Operation.....	50
Dental light	51
Available settings	51
Cuspidor, including glass filler and bowl.....	52
Available settings	52
Factory settings.....	52
Operation of glass filler and bowl on the instrument table	52
Operation of glass and bowl on the top of the console.....	53
Warnings, top of console.....	53
Spittoon valve.....	54
Available settings	54
Operation of Metasys cuspidor valve	54
Operation of Dürr spittoon valve	54
Suction tube.....	55
Available settings	55
Factory settings.....	55
Suction.....	56
Operation of suction.....	56
Removal of suction cannula	56
Removal of suction holders.....	56
Removal of filter for suction hoses.....	56
Adjustment of telescopic arm.....	56
Air/water separator.....	57
Available settings	57
Model Dürr air/water separator	57
Function	57
Operation.....	57
Warnings.....	57
Cleaning.....	57
Model Metasys air/water separator	57
Function	57
Operation.....	57
Warnings.....	57
Cleaning.....	57
Dürr amalgam separator	58

Function	58
Operation.....	58
Cleaning	58
Warnings	58
Metasys amalgam separator	60
Function	60
Operation.....	60
Cleaning	60
Warnings	60
Locking of Heka G+ in connection with cleaning.....	62
Available settings	62
Factory settings.....	62
Display for locking of Heka G+	62
Operation.....	62
Cleaning & disinfection	63
Cleaning & Disinfection of clinical contact surfaces	63
First, CLEANING	63
Then, DISINFECTION	63
Cleaning & Disinfection of external surfaces	64
CLEANING.....	64
DISINFECTION	64
Precautions	64
Attaching and removing the handle	64
Lamp head and dish.....	64
Attaching and removing the cuspidor glass bowl.....	64
Cleaning & Disinfection of the patient chair upholstery	65
First, CLEANING	65
Then, DISINFECTION	65
Suction hose cleaning system.....	66
Available settings	66
Factory settings.....	66
Operation.....	66
Error display	67
Fluid refill.....	67
Instrument flush using water	68
Available settings	68
Factory settings.....	68
Operation.....	68
Error display	68

Maintenance.....	69
Removal of the instrument supports.....	69
Service	70
Annual service	70
Annual service checklist.....	71
Printed and electronic information	73
IT requirements.....	74
Security	74
Heka One Connect WEB interface.....	75
Technical guidelines - only for authorised technicians.....	76
Technical data.....	76
Fuses 76	
Power board.....	76
Console Controller board	76
Service and maintenance	76
Service and maintenance	77
Installation requirements.....	77
Classification of equipment.....	78
Compliance with regulatory standards	78
Wireless foot controls, technical specifications	79
Monitor.....	79
Hydraulic diagram	80
Special conditions in connection with connected Heka G+ and Heka Patient Chair	81
Communication overview.....	82
Block diagram.....	82
General technical information	83

Warnings and error descriptions from the system.....	84
Component & Performance Specification.....	85
Main Unit.....	85
Foot Control.....	85
Heka Patient Chair.....	86
Possibility of contact with parts occurring.....	87
Warranty Terms & Conditions.....	88
Exchangeable parts.....	89
IFUs and Label Language Requirements.....	89
Installation/Service card.....	90
EMC Informations.....	91
Disposal of the unit.....	95

Note: With reservation of technical changes and colour changes. Images may be displayed with optional equipment. Images may be displayed without safety labels.

Introduction

Congratulations on your new Heka treatment unit.

We are delighted that you have chosen Heka Dental as your supplier for your practice.

Our goal is to be able to meet your needs and wishes by creating innovative solutions that help you in your daily work.

Together with your service partner, you have configured your Heka treatment unit so that it best suits your requirements. If you wish to change the configuration, this is easily done via our Heka One Connect software.

As our equipment generally has a long lifetime and new options are added regularly, we have made it easy for you to update your Heka treatment unit in the future.

Heka features simple controls and innovative, high-quality solutions and designs that help and support you in your daily treatments.

These operating instructions are designed to help you before you begin treatment - and when you need information later.

We wish you all the best with your Heka.

Kind regards,

Your Heka Dental Team.

Heka Dental A/S is ISO 13485 certified.

Description

Heka G⁺ is an electronically controlled dental device used by trained dental operators for the prevention and treatment of illnesses in the oral cavity of humans.

The unit consists of a floor-mounted console with a fountain, telescopic suction arm, movable balanced arm for the instrument table and operating lamp.

The free-standing Patient Chair⁺ is connected to the floor-mounted console.

The instruments are individually balanced with springs, making them easy to use and the extra-long silicone connection tubes are designed for use in various working positions.

The instrument status can be read in a central location using a display on the instrument table.

Heka G⁺ is intended for dental treatment performed by trained dental personnel.

Heka G⁺ is intended for dental treatment in dentist clinics placed near home facilities or in hospitals.

These operating instructions describe how to use the Heka G⁺ device, and it is therefore essential to thoroughly read the instructions prior to using the device.

These instructions form the primary source of information in the event of errors or operating issues.

Please refer to the OEM documentation for information about OEM products.

Intended Purpose

Heka Family systems are dental units. The system is intended for use in dental care treatments.

The system is to be used by authorized professionals within the scope of his/her education, training, and experience. The system provides the dental practitioner a motorized patient chair, dental instruments, and suction system for removal of bodily fluids.

Indications for use









Dental care medical operations include evaluation, diagnosis, prevention and/or treatment of diseases, disorders and/or conditions of the oral cavity, maxillofacial area and/or the adjacent and associated structures and their impact on the human body.







Contraindications

There are no known contraindications for the use of this equipment.

Warnings and precautions

Heka Dental assumes no responsibility for direct or indirect consequential damage resulting from improper use or arising through inadequate compliance with the operating instructions, or incorrect use and maintenance.

	<p>Use only as intended. Inadequate compliance with the operating instructions could result in serious injury to the patient or user or irreparable damage to the equipment. Before using this product, please ensure that you have read and understood the operating instructions.</p>
	<p>Must be used by qualified and trained dental personnel only.</p>
	<p>Do not install the equipment in areas where there is a risk of explosion. Heka G⁺ is not intended for operation in oxygen rich environments or in the presence of flammable anesthetics or gases.</p>
	<p>Clean, disinfect, and sterilize new or repaired handpieces and instruments before first use and between each patient use. Only use sterilized handpieces and instruments during treatment. Non-sterilized handpieces and instruments may cause bacterial or viral infections. Always sterilize handpieces and instruments after operation</p>
	<p>Please see the section on approved cleaning agents and methods for a detailed description of cleaning methods and maintenance for the Heka G⁺. See enclosed OEM instructions for cleaning and maintenance of any OEM equipment and instruments.</p>
	<p>Always operate high-speed handpieces with water coolant. Operating a high-speed handpiece without water coolant can cause thermal injury to the patient.</p>
	<p>Do not use this equipment for the treatment of implants.</p>
	<p>The water used by the Heka G⁺ device's instruments and water glass filler is exclusively intended for rinsing.</p>
	<p>The main tap for water and air <u>must</u> be turned off when the device is not in use.</p>

	<p>Electromagnetic Compatibility (EMC) Changes or modifications to this product not expressly approved by Heka Dental A/S may result in increased emissions or decreased immunity performance of the product and could cause EMC issues with other equipment. This product is designed and tested to comply with applicable regulation regarding EMC and shall be installed and put into service according to the EMC information stated below:</p>
	<p>Use of portable phones or other portable or mobile radio frequency (RF) emitting equipment near the product may cause unexpected or adverse operation such as patient lamp flickering or shut off.</p>
	<p>In the event of high-voltage emission ESD (8-15KV), the display on the handle for the suction tube holder can be turned off. The function keys will continue to work. The display will work again by turning the device off and on again.</p>
	<p>Portable RF communication equipment must be used only at a minimum distance of 40 cm (15 inches) from any part of the [ME EQUIPMENT or ME SYSTEM], including cables, as specified by manufacture.</p>
	<p>The use of accessories, transducers and cables and items other than those supplied with the equipment may result in increased emission and reduced immunity or performance of the product. Heka G⁺ must not be used next to or stacked with other equipment. If such use is necessary, the user will be responsible for testing that the configuration is safe for use during normal treatment. Detailed information about electromagnetic interference in relation to the Heka G⁺ starts in section EMC Information in these instructions. See EMC Information for recommended distances between the Heka G⁺ and other electronic devices.</p>
	<p>Don't let suction or handpieces, - including magnets, come near patients with implanted pacemakers.</p>
	<p>Don't touch the patient while you are handling the equipment in the service compartment or other internal parts of the dental unit.</p>

Cautions

CAUTION	This equipment is only to be sold by or on the order of a dentist and only used in accordance with these operating instructions and exclusively by trained professional dental operators.
CAUTION	Position the equipment with sufficient area from walls or obstructions to easily operate and disconnect the device See of the Heka G ⁺ Installation Manual for the dimensions and space requirements of the equipment
CAUTION	Do not position or stack other equipment on the dental unit. See the Heka G ⁺ Installation Manual for the dimensions and space requirements of the equipment
CAUTION	Always inspect the equipment components for damage before performing treatment. Damaged components must not be used and must be replaced before further use of the equipment.
CAUTION	Thoroughly read the documentation for the OEM products that are supplied with Heka G ⁺ before they are connected and used.
CAUTION	Prior to use this equipment, instruments, suction tubes and water supply hoses must be flushed and cleaned in accordance with the operating instructions.
CAUTION	Ensure compliance with local requirements concerning the removal of Amalgam waste.
CAUTION	Do not use saline solutions in the water system, as saline causes the formation of rust in the filters.
CAUTION	Ultrasound cleaning is not suitable for this equipment.
CAUTION	Micro Motor should be removed from the tubing and cleaned every day to avoid corrosion.
CAUTION	The user is responsible for ensuring that the equipment is subjected to annual maintenance and must ensure that the functions of the equipment do not change over time.
CAUTION	The Heka G ⁺ device must be used only under the supervision of trained professional dental operators.
CAUTION	According to international standard: IEC 80601-2-60 Clause 201.4.3 Essential Performance: Dental equipment and hereby Heka Dentals dental equipment, does not have Essential Performance.

Additional Safety Information

The use of accessories that do not comply with the safety regulations for this type of equipment may compromise the safety of the entire system. Therefore, the following must be taken into consideration:

Use of instruments

Documentation of the safety certificates for accessories must be in accordance with the applicable international IEC 60601-1 and the current ISO 7494.

A complete list of standards that the Heka G⁺ treatment device complies with can be seen in the section “Compliance with regulatory standards” later in this instruction.

The Heka G⁺ device complies with all requirements set down in Directive 93/42/EEC.



IMPORTANT!

To ensure the safety, reliability, and functionality of this Equipment:

Use only qualified and authorized technicians for installation, calibration, modification, and repair of the Heka G⁺

Compliance with IEC 60364 for all electrical installations

Use of only authorized OEM instruments

Use this Equipment only in accordance with instructions provided in this manual

The USB port are only for charging.

The monitors signal cables should only be connected to equipment certified according to IEC 60601-1, IEC 60950-1 or IEC 62368-1.

DO NOT:













- Attempt to modify this equipment without authorization by Heka Dental A/S
- If modification is made, the equipment must be fully tested and inspected by a Certified Heka Dental technician prior to use, to ensure safety









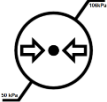
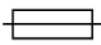
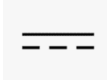

Regulatory classification

- MDR classification: Class IIa for Dental Delivery System, and Class I for Dental patient chair
- Type B Applied Parts
- Ordinary Protection









Not suitable for use in the presence of flammable mixed anaesthetic gases such as air, oxygen or laughing gas (nitrous oxide).

Symbols

Symbols	Description
	Type B Equipment
	Alternating Current
	General CAUTION! (Standard ISO 7010) See enclosed documents and/or catalogues
	Protective earth
	Folliw instructions for use
	Foot control
	Separate collection of electrical and electronic equipment in accordance with Directive 2002/96/EEC (WEEE).
	Temperature Limitations
	Keep dry
	This side up
	Do not use hand hooks
	Fragile
	No rotation

	Stacking limitations
	Limitations on Relative Humidity
	Limitations on Pressure
	Fuse
	Direct Current
	Do not open
	Operating Instructions
	In house use
	Class II equipment
	Manufacturer
	Country of manufacturer
	Medical device
	Unique device identifier

Symbols on packaging material

	This side up (IEC 60417)
	Do not open (ISO 7010)
	Keep dry (ISO 15223-1)
	No rotation (ISO 7000)
	Do not use hand hooks (ISO 7000)
	Temperature Limitation (ISO 15223-1)
	Stacking limitation (IEC 60714)
	Humidity limitation (ISO 15223-1)
	Atmospheric pressure limitation (ISO 15223-1)

Transport and stock conditions

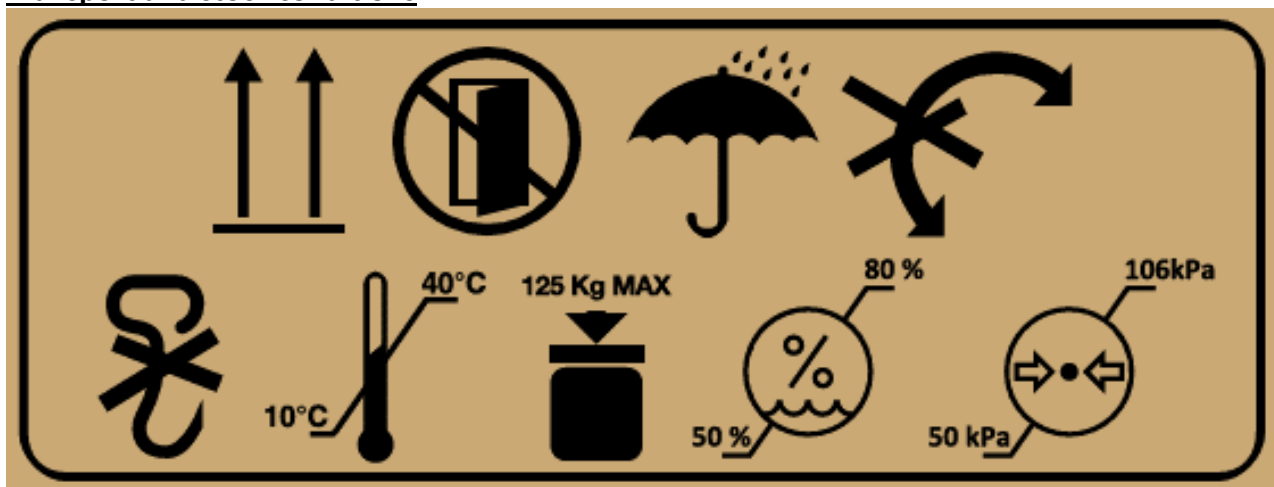

Heka G⁺ overview

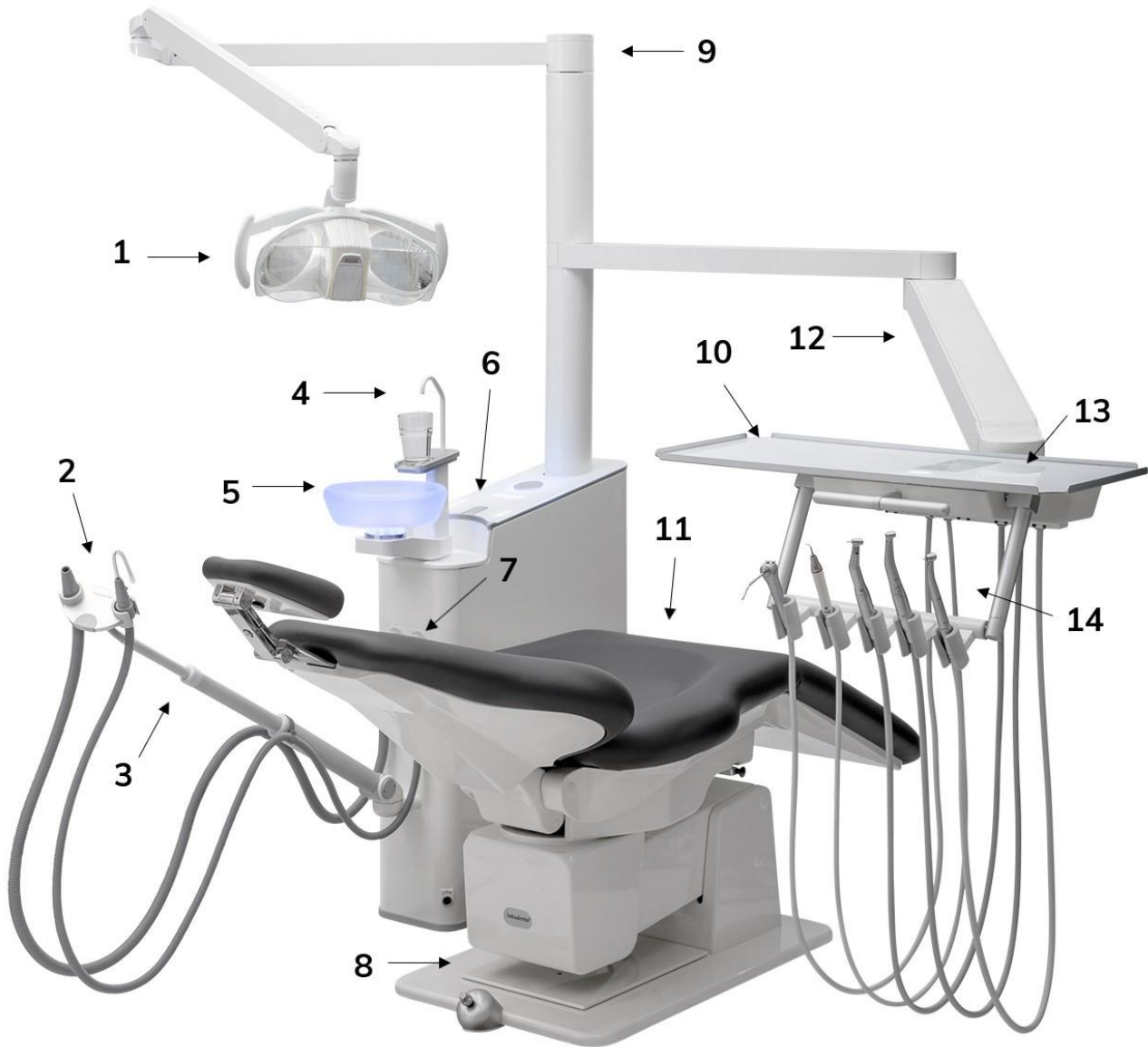

1	Operating lamp	6	Console keyboard	11	Patient chair
2	Suction	7	Suction filters	12	Arm system w. table
3	Telescope arm	8	Emergency stop	13	Instrument table display & keyboard
4	Cup filler	9	Lamp adaptor	14	Instruments
5	Bowl	10	Tray		

Components

The following Heka G⁺ components have been produced by Heka Dental A/S:

- Floor-mounted console
- Instrument arm, instrument table, tray.
- Instrument table display
- Cuspidor
- Telescopic suction arm and hoses
- Foot controls
- Water bottle
- Free-standing patient chair

Installation, operating, maintenance and cleaning information for the aforementioned components can be found in these instructions.

Special equipment and instruments

Special equipment and instruments for use together with Heka Dental Heka G⁺ can be purchased separately.

If you have purchased any of the optional equipment and instruments for use with your Heka G⁺, please refer to the enclosed OEM documentation that contains information about installation, use, maintenance and cleaning of the devices.

Accessories

Monitor

Single tray

Double tray

Suction Cannula 11 mm

Suction Cannula 15 mm



Starting up the Heka G⁺

The display descriptions in these operating instructions are based on the factory settings. The display can be adapted individually for each user and depends on the number of user and user profiles.

Please refer to section below.

Press the main switch at the bottom rear of the console to turn the Heka G⁺ on and off.

When booting, the instrument table display will show:
Heka

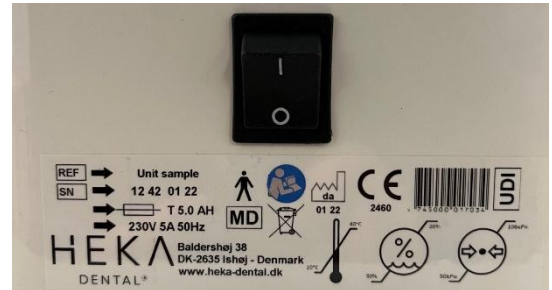

Any messages relating to servicing, etc., will subsequently be shown. To remove any messages, give a short press on the arrow RIGHT key.

Multi-dentist and multi-treatment

A total of 30 dentists and a total of 99 dentist treatments can be created.

When a dentist has been set up

Enter Treatment select menu by pressing the  icon.

Heka G⁺ will show the following on the instrument table display depending on set-up and type of unit.

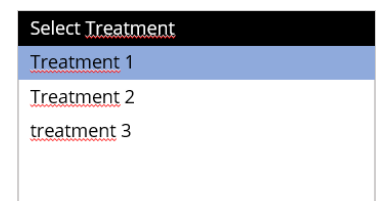
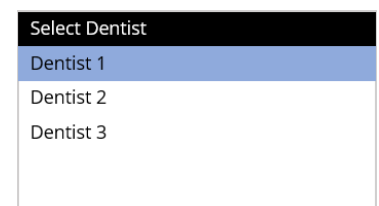
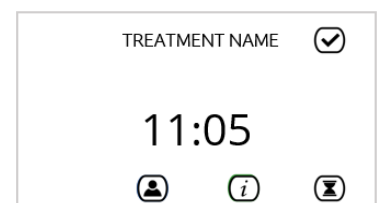

In case multiple dentists are setup

Select the dentist using arrow UP or DOWN and press the arrow RIGHT to confirm the dentist selection.

First select the dentist and then the treatment and confirm using the arrow RIGHT.

It is possible to choose another treatment by pressing the TREATMENT NAME.

Online user registration for dentists

Register as a user of a Heka unit

Access special product information

Scan the QR code for online registration.

You can e.g. access special software, user guides, quick guides, user guides videos, tips & tricks, product news, etc. We are constantly expanding the possibilities for registered users of Heka units.

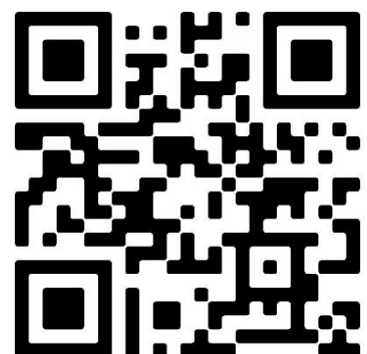

Heka ID

If Heka ID is installed, it has two functions:

- is used as an easy way to select a dentists treatment
- a key to lock and unlock the unit



To use your Heka ID card, simply place the card close to the reader located under the instrument table joint and the unit will switch to your treatment settings. If your treatment is active, the unit will go into standby mode when the card is read, where all inputs are disabled, and main valves switched off.

Heka G⁺ is now ready for use.

The main valves for water and air will be turned on automatically when the device is turned on.





In an emergency, use the main switch to turn off the Heka G⁺

Foot controls

Three different foot control types are available, and they have different options for controlling the treatment unit's instruments.

Options in relation to controls:

	 Standard round	 Standard variable	 Universal
Programs	Yes, up to nine programs.	Yes, up to nine programs.	Yes, up to nine programs.
Activation of instruments	Yes, push the activation ring fully in.	Yes, by moving the pedal arm towards the right.	Yes, either by pressing the pedal arm or by moving the pedal arm towards the right.
Continuously variable speed control.	No, but speed can be adjusted by turning the activation ring	Yes.	Yes.
Switching between programs.	Yes, standard: double tap on the middle ring. Option: double tap on the activation ring.	Yes, standard: double tap on the middle ring.	Yes, standard: double tap on either ear.
Changing the direction of rotation	No. Reversed rotation direction is chosen on Instrument table keyboard.	No. Reversed rotation direction is chosen on Instrument table keyboard.	No. Reversed rotation direction is chosen on Instrument table keyboard.
Changing instrument spray	Yes	Yes	Yes
Mechanical chip-blow	Yes	Yes	Yes
Turn the OP lamp on/off	Yes	Yes	Yes
Assistant call	Yes	Yes	Yes
Wireless or wired	Yes	Yes	Yes
Controlling the patient chair	No	No	Yes

The operating instructions are based on standard round foot controls.

Standard wireless foot control

As standard, Heka G⁺ is supplied with round, patented wireless foot control.



1	OP Lamp ON/OFF	3	Activation ring	5	Increase
2	Decrease	4	Battery indicator when charging	6	Middle ring: Spray selector/Mechanical chip-blower

Mode of operation for standard foot controls:

Operation:	Location:	Action:
Activate OP lamp	Top of foot controls	Short press
Assistant call	Top of foot control	Long press
Activation of selected instrument	Activation ring	Press.
Switching between programs, normal	Yes, standard: double tapping on the middle ring.	Two short presses
Switching between programs, option*	Activation ring	Two short presses
Activating the mechanical chip-blow. The chip-blow will remain active for as long as pressure is maintained.	Middle ring	Long press (>1 second)

*Can be configured via the WEB interface.

Standard variable wireless foot control

Heka G⁺ can be supplied with standard variable wireless foot control.



1	OP Lamp ON/OFF	3	Pedal arm	5	Increase
2	Decrease	4	Battery indicator when charging	6	Middle ring: Spray selector/Mechanical chip-blower

Mode of operation of standard variable foot controls:

Operation:	Location:	Action:
Activate OP lamp	Top of foot controls	Short Press
Assistant call	Top of foot controls	Long press
Activation of lifted instrument	Pedal arm	Pedal arm towards the right
Switching between programs, normal	Middle ring	Two short presses
Switching between programs, option	Activation ring	Two short presses
Changes the spray selection of the activated instrument	Middle ring	Short press (<1 second)
Activating the mechanical chip-blower. The chip-blower will remain active for as long as pressure is maintained.	Middle ring	Long press (>1 second)
Increase intensity in the instrument	Pedal Arm	Press towards the right
Decrease intensity in the instrument	Pedal Arm	Press towards the left

Universal variable foot control

Heka G⁺ can be supplied with an universal variable wireless foot control.

If Heka G⁺ has been supplied with an universal variable foot control, there are up to nine programs
 - See section: Set-up Universal variable foot control.

Speed is configured using the pedal arm, but the speed range is configured using up to nine programs.

Configuring the pedal springs:



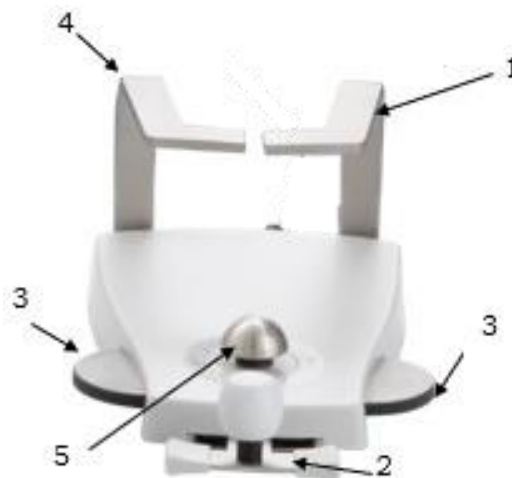









Under the foot control, the pedal spring can be turned on or off by holding the pedal arm at the max. position while either inserting or removing the screw. (Screw the screw in only so far that it is not touching the base plate).













Mode of operation for universal foot controls:



Operation:		Location:	Action:
Activate OP lamp	1	Left hand bracket	Press
Assistant call	4	Right hand bracket	Press
Activation of selected instrument	2	Activation of pedal arm	Via Pedal arm
Switching between programs	3	Spray selection (right or left ear)	Two short presses
Changes the spray selection of the activated instrument	3	Spray selection	Short press (<1 second)
Activates the mechanical chip-blower. The chip-blower will remain active for as long as pressure is maintained.	3	Spray selection	Long press (>1 second)
Greater intensity in the instrument	2	Pedal Arm	Press/move towards the right
Less intensity in the instrument	2	Pedal Arm	Press/move towards the left
Joystick for controlling the chair.	5	See instructions for the chair.	

Instrument table display





Symbol	Description
	Standby mode, to unlock press and hold arrow RIGHT and UP simultaneously, or log in with Heka ID
	Display/device locked in connection with cleaning
	Dentist / Treatment selection, activated by pressing the icon on the instrument table display
	Dentist / Treatment selection using Heka ID card
	Public water supply, activated using the switch on the bottled water system
	Bottled water (bottle) connection, activated using the switch on the bottled water system
	Information menu, activated by pressing the icon on the instrument table display
	Select program timer menu
	A warning that requires attention. The warning is described in detail by pressing the icon on the instrument table display
	Spray air OFF, - can be activated via the foot controls or by pressing the screen symbol on the instrument table display
	Spray air ON, - can be activated via the foot controls or by pressing the screen symbol on the instrument table display
	Spray water OFF, - can be activated via the foot controls or by pressing the screen symbol on the instrument table display
	Spray water ON, - can be activated via the foot controls or by pressing the screen symbol on the instrument table display

	Assistant call
	Gearing of angle-piece
	The torque value is displayed to the left of the icon.
	Dental light
	Normal motor rotation
	If the endo rotation mode auto reverse is selected, the motor direction will automatically be reversed when the predefined torque level is reached.
	As auto reverse, but after a predefined time of reversed rotation, the direction will automatically be switched back to normal rotation. In connection with right rotation, the motor may switch to left rotation, when an adjustable torque limitation has been reached (from 10% to 100% of maximum torque) the motor's direction of rotation will change to left rotation.
	Reciprocating option for MX2 micromotor. Require license *WaveOne® is a registered trademark of Dentsply Sirona Inc
Speed	Flashes in connection with reverse rotation of the motor
	Automatic chip blow will open the air spray air for the pre-defined chip blow time. The automatic chip blow time is displayed beside the icon.
	Settings key where you can save chair settings, adjust time, set bowl flush and cup fill time
	Optional: Sterile water system connected; flow percentage is displayed next to the symbol



Description of the instrument table touch keys

	Automatic rinsing function (touch function)
	Call assistant (touch function)
	Chair controls





The following arrow displays may, depending on the situation, be used to operate the patient chair, instruments or other functions described in these operating instructions.

	Arrow UP
	Arrow DOWN
	Arrow LEFT/Cancel
	Arrow RIGHT/accept

Description of the console top keys

C	Automatic and manual suction cleaning
	Manual cup filling. The cup will be filled while the key is activated
	Manual bowl flush. The bowl will be flushed while the key is activated
	Chair controls

The following arrow displays may, depending on the situation, be used to operate the patient chair, instruments or other functions described in these operating instructions.

	Arrow UP
	Arrow DOWN
	Arrow LEFT/Cancel
	Arrow RIGHT/Accept

Turbine instrument

Available settings

Programs	1 to 9 individual programs with individual names.
With individual configuration of the following:	
Spray	No spray, air spray, air- and water spray, water spray.
Sterile water	From 0% to 100%. (Sterile water supply is possible depending on the instrument model).
Speed range	From 1% to 100% (applicable to variable turbine instruments).
Chip-blower	0 to 9 seconds.
General settings:	
Instrument light intensity	From 0% to 100%. (Possibility of adjusting instrument lighting depends on instrument model)
Dental light intensity	From 1% to 100% (Possibility of adjusting brightness depends on the type of operating lamp)
Dental light colour	The possibility of adjusting light colour depends on the type of dental light.
Display	Full or selective display.
Switching between programs	Standard: Double tap on the middle ring. Option: Double tap on the activation ring (Will give a delay)

Factory settings

Individual configuration	Program 1
Program name	Turbine Standard
Spray	Air-water spray
Sterile water	Not active.
Intensity range	100% (not displayed)
Chip-blower	2 seconds
General configuration	
Instrument light intensity	100% (not displayed)
Dental light intensity	100% (not displayed)
Display	Normal display

The settings can be changed via the Web interface, - please refer to the Web interface guide.

Turbine instrument display

The display example shows the following:

Program is labelled "Program 1"

Automatic chip blow is set to 2.0 seconds

Air and water spray is active

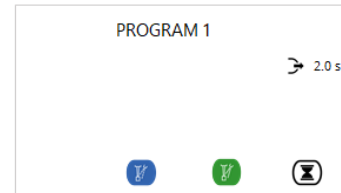

Operation

When the instrument is selected, the instrument table display will change to the instrument program in the active treatment. If the instrument is equipped with a fiberoptic light, this will be turned on automatically. In this mode you can change program settings. The instrument is subsequently activated using the foot control.

If selective display has been chosen, the instrument table display will only show the information that has been selected for the ongoing active treatment.

Changing the spray function

The instrument must be selected to change the spray combinations. You can subsequently change between the available spray combinations by tapping the middle ring on the foot control.

The spray combination can be read from the instrument table display in the form of spray symbols and the projection onto the patient's chest.

If water spray is enabled, the automatic chip blow will also be enabled. The duration can be changed, or the function disabled entirely via the instrument table display, instrument table keyboard or via the Web interface. Mechanical chip blow is achieved by pressing and holding the middle ring on the foot control. The mechanical chip blow is activated while the middle ring is being pressed.

Water and air adjustments

Regulating cocks are installed under the turbine instrument for:

Regulating cock	Regulating of	Clockwise turning	Anti-clockwise turning
Blue	Air spray	Reduction	Increase
Green	Water spray	Reduction	Increase
Neutral	Drive or cooling air	Reduction	Increase

Drive or cooling air is configured during installation and should not be changed.



The return air container is located in the console and does not require any maintenance.



Regarding use and operating times, please refer to the regulations issued by the instrument manufacturer

Motor instrument

Available settings

Programs	1 to 9 individual programs with individual names.
With individual configuration of the following (depending on motor type):	
Gearing	20:1 to 1:20 (not used)
Torque	10% to 100%.
Rotation mode	Normal, auto-reverse, auto-forward. (only with MX2 motors)
Spray	No spray, air spray, air-water spray, water spray.
Sterile water	From 0% to 100%. (Sterile water supply is possible depending on the instrument model).
Speed range	This is the actual motor rotation, - it is also important to take any gearing into account. From 100 to 40,000 (Bien Air MCX/MX3/MX-i motor with DMX3 CAN controller) From 1,000 to 40,000 (Bien Air MCX motor with analogue controller)
Automatic chip-blower	0 to 9 seconds
General settings:	
Instrument light intensity	From 0% to 100%. (Possibility of adjusting instrument lighting depends on instrument model)
Dental light intensity	From 1% to 100% (Possibility of adjusting brightness depends on the type of operating lamp)
Dental light colour	The possibility of adjusting light colour depends on the type of dental light.
Display	Full or selective display.
Switching between programs	Standard: Double tap on the middle ring. Option: Double tap on the activation ring (Will give a delay)

Factory settings

Individual configuration	Program 1
Program name	Prg 1
Spray	Air-water spray
Sterile water	Not active.
Speed range	From 1000 to 40000
Gearing	1:1
Torque	60
Rotation mode	normal
General configuration	
Fibre light intensity	100% (not displayed)
Operating light intensity	100% (not displayed)
Display	Normal display

The settings can be changed via the Web interface, - please refer to the Web interface guide.

Motor instrument display

The display example shows the following:

Torque set to 100%

The Program is labelled "Program 1"

Sterile water flow has been set to 80%

Rotation mode set to auto forward

Gearing has been set to 1:2

Automatic chip blow has been set to 2.0 seconds

Speed range: minimum 1000 and maximum 40000

Current speed is set to 23000 rpm

Air and water spray air is active

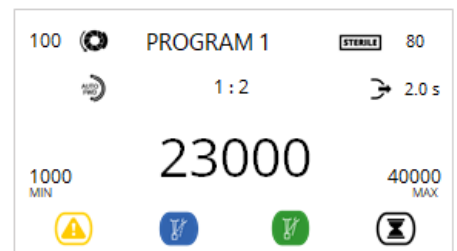

Operation

When the instrument is selected, the instrument table display will change to the instrument program in the active treatment. If the instrument is equipped with a fiberoptic light, this will be turned on automatically. In this mode you can change program settings. The instrument is subsequently activated using the foot control.

If selective display has been chosen, the instrument table display will only show the information that has been selected for the ongoing active treatment.

As standard, the motor instrument is supplied with one program with individual settings. You can switch between the programs by double-tapping the middle ring on the foot control.



Manual adjustment of the motor speed

The motor speed is increased by turning the activation ring on the foot controls anti-clockwise, speed is reduced by turning the activation ring on the foot controls clockwise.

By pressing the actual speed, min or max speed, you can change the values in the actual treatment. Save the setting by pressing actual speed followed by .

Torque

The motor controls have built-in torque, which means that the tractive force is increased when the drill is under load in order to maintain the rotational speed. Rotation mode can be read on the instrument table display

Mode display	Description	Notes
	Normal	The tractive force is increased when the drill is under load in order to maintain the rotational speed.
	Auto-reverse	If the Endo rotation mode Auto Reverse is selected, the motor direction will automatically be reversed when the predefined torque level is reached. In connection with left rotation, the motor may alternately change to right rotation for an adjustable period of 0-5 seconds.
	Auto-forward	As Auto Reversed, but after a predefined time of reversed rotation, the direction will automatically be switched back to normal rotation. In connection with right rotation, the motor may switch to left rotation, when an adjustable torque limitation has been reached (from 10% to 100% of maximum torque) the motor's direction of rotation will change to left rotation.
	WaveOne*	Reciprocating option for MX2 micromotor. Require license.

The torque mode for the individual programs is configured in the WEB interface.

*WaveOne® is a registered trademark of Dentsply Sirona Inc.

Direction of rotation

With the motor selected, a short press on the arrow LEFT icon will change the direction of rotation of the motor. The change is confirmed by three beeps and the speed value will start to flash on the instrument table display. To return to the normal direction of rotation, the motor must be returned to the instrument holder or a short press of the ARROW right icon.

Changing the spray combinations

The instrument must be selected to change the spray combinations. You can subsequently change between the available spray combinations by tapping the middle ring on the foot control.

The spray combination can be read from the instrument table display in the form of spray symbols and the projection onto the patient's chest.

If water spray is enabled, the automatic chip blow will also be enabled. The duration can be changed, or the function disabled entirely via the instrument table display, instrument table keyboard or via the Web interface. Mechanical chip blow is achieved by pressing and holding the middle ring on the foot control. The mechanical chip blow is activated while the middle ring is being pressed.

Water and air adjustment

Regulating cocks are installed under the motor instrument for:

Regulating cock	Regulating of	Clockwise turning	Anti-clockwise turning
Blue	Air spray	Reduction	Increase
Green	Water spray	Reduction	Increase
Neutral	Drive or cooling air	Reduction	Increase



Cooling air is configured during installation and should not be changed.



Regarding use and operating times, please refer to the regulations issued by the instrument manufacturer.

Ultrasonic scaler

Available settings

Programs	1 to 9 individual programs with individual names.
With individual configuration of the following:	
Spray	No spray, water spray.
Sterile water	From 0% to 100%. (Sterile water supply is possible depending on the instrument model).
Intensity range:	From 1% to 100%
Intensity range in Category:	From 1% to 100%
General settings:	
Instrument light intensity	From 0% to 100%. (Possibility of adjusting instrument lighting depends on instrument model)
Dental light intensity	From 1% to 100% (Possibility of adjusting brightness depends on the type of operating lamp)
Dental light colour	The possibility of adjusting light colour depends on the type of dental light.
Display	Full or selective display.
Switching between programs	Standard: Double tap on the middle ring. Option: Double tap on the activation ring (Will give a delay)

Factory settings

Individual configuration	Program 1
Program name	Prg 1
Spray	water spray
Sterile water	Not active.
Intensity range	From 1% to 100%
General configuration	
Instrument light intensity	100% (not displayed)
Dental light intensity	100% (not displayed)
Display	Normal display

The settings can be changed via the Web interface, - please refer to the Web interface guide.

Ultrasonic scaler display

The display example shows the following:

Spray water is active

Intensity is 21% of maximum

Intensity range: minimum 10% and maximum 50%

Program 1

Spray water is active

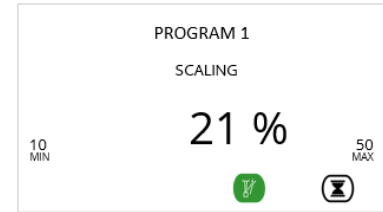

Operation

When the instrument is selected, the instrument table display will change to the instrument program in the active treatment. If the instrument is equipped with a fiberoptic light, this will be turned on automatically. In this mode you can change program settings. The instrument is subsequently activated using the foot control.

If selective display has been chosen, the instrument table display will only show the information that has been selected for the ongoing active treatment.

As standard, the ultrasonic scaler is supplied with one program with individual settings. You can switch between the programs by double-tapping the middle ring on the foot control.

When the instrument is selected, the intensity can be adjusted using the arrow UP and DOWN keys on the instrument table or the foot control depending on the settings made during installation. . From 1.5 software you can, by pressing the actual intensity, min or max intensity, change the values in the actual treatment. Save the setting by pressing actual speed followed by .

The intensity categories are defined individually in accordance with the ultrasonic tooth cleaner instrument manufacturer:

W&H PB-5:	10 on the W&H scale corresponds to 25% of max. the intensity. 20 on the W&H scale corresponds to 50% of max. the intensity. 30 on the W&H scale corresponds to 75% of max. the intensity. 40 on the W&H scale corresponds to 100% of max. the intensity.
Acteon Newtron:	Green corresponds to 10-25% of max. the intensity Yellow corresponds to 26-50% of max. the intensity Blue corresponds to 51-75% of max. the intensity. Orange corresponds to 76-100% of max. the intensity.
NSK Varios:	1-100%
EMS Piezon:	1-100%

Changing the spray function

The instrument must be selected to change the spray combinations. You can subsequently change between the available spray combinations by tapping the middle ring on the foot control.

The spray combination can be read from the instrument table display in the form of spray symbols and the projection onto the patient's chest.

If water spray is enabled, the automatic chip blow will also be enabled. The duration can be changed, or the function disabled entirely via the instrument table display, instrument table keyboard or via the Web interface. Mechanical chip blow is achieved by pressing and holding the middle ring on the foot control. The mechanical chip blow is activated while the middle ring is being pressed.

Water adjustment

A regulating cock has been installed under the ultrasonic tooth cleaner for:

Regulating cock	Regulating of	Clockwise turning	Anti-clockwise turning
Green	Spray water	Reduction	Increase



Regarding use and operating times, please refer to the regulations issued by the instrument manufacturer.

Air ultrasonic scaler

This instrument can be installed with a variable valve as an option. In this case only the intensity will be displayed.

Available settings

Programs	1 to 9 individual programs with individual names.
With individual configuration of the following:	
Spray	No spray, water spray.
Sterile water	From 0% to 100%. (Sterile water supply is possible depending on the instrument model).
Intensity:	From 1% to 100%
General settings:	
Instrument light intensity	From 0% to 100%. (Possibility of adjusting instrument lighting depends on instrument model).
Dental light intensity	From 1% to 100% (Possibility of adjusting brightness depends on the type of operating lamp).
Dental light colour	The possibility of adjusting light colour depends on the type of dental light.
Display	Full or selective display.
Switching between programs	Standard: Double tap on the middle ring. Option: Double tap on the activation ring (Will give a delay).

Factory settings

Individual configuration	Program 1
Program name	Prg 1
Spray	water spray
Sterile water	Not active.
Intensity range	From 1% to 100%
General configuration	
Instrument light intensity	100% (not displayed)
Dental light intensity	100% (not displayed)
Display	Normal display

The settings can be changed via the Web interface, - please refer to the Web interface guide.

Air display, Ultrasonic scaler

The display example shows the following:

The Program is labelled "Program 1"

Intensity range: minimum 10% and maximum 50%

Intensity is 21% of maximum

Spray water is active

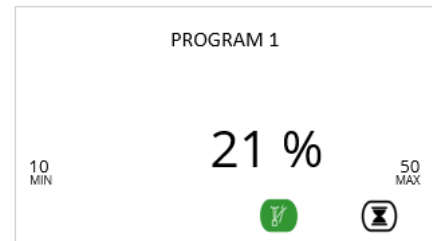

Operation

When the instrument is selected, the instrument table display will change to the instrument program in the active treatment. If the instrument is equipped with a fiberoptic light, this will be turned on automatically. In this mode you can change program settings. The instrument is subsequently activated using the foot control.

If selective display has been chosen, the instrument table display will only show the information that has been selected for the ongoing active treatment.

As standard, the ultrasonic scaler is supplied with one program with individual settings. You can switch between the programs by double-tapping the middle ring on the foot control.

When the instrument is selected, the intensity can be adjusted using the foot control. From 1.5 software you can, by pressing the actual intensity, min or max intensity, change the values in the actual treatment. Save the setting by pressing actual speed followed by .

Changing the spray function

The instrument must be selected to change the spray combinations. You can subsequently change between the available spray combinations by tapping the middle ring on the foot control.

The spray combination can be read from the instrument table display in the form of spray symbols and the projection onto the patient's chest.

Water adjustment

A regulating cock has been installed under the ultrasonic tooth cleaner for:

Regulating cock	Regulating of	Clockwise turning	Anti-clockwise turning
Green	Spray water	Reduction	Increase



Regarding use and operating times, please refer to the regulations issued by the instrument manufacturer.

Light polymerisation instrument

There are three types of Light polymerization instruments:

With button where the dentist activates the polymerization light by pressing a button on the instrument. In this case the curing duration is controlled by the instrument itself.

The instrument table display will show a timer that can be used as an info for the dentist. With a Heka Bluedent polymerization instrument, you can start the polymerization and timer at the same time on the foot control or touch display.

You can always deactivate the polymerization light before timeout by placing the instrument back in the resting position.

Without button where the dentist activates the polymerization light using the foot control or by pressing the icon on the instrument table display. In this case the curing duration is controlled by the chosen program. The display will show the timer countdown. You can always deactivate before timeout by placing the instrument back in the resting position. See Operation section below

Available settings

Programs	1 to 9 individual programs with individual names.
With individual configuration of the following: Light polymerization time	0 to 60 seconds
With general configuration of the following: Dental light intensity	From 1% to 100% (Possibility of adjusting brightness depends on the type of operating lamp).
Dental light colour	The possibility of adjusting light colour depends on the type of dental light.
Display	Full or selective display.
Switching between programs	Standard: Double tap on the middle ring. Option: Double tap on the activation ring (Will give a delay).

Factory settings

Individual configuration	Program 1
Instrument light intensity	100% (not displayed)
Dental light intensity	100% (not displayed)
Dental light colour	Composite mode (EVA lamp)
General configuration	
Dental light intensity	Low level
Display	Normal display

The settings can be changed via the Web interface, - please refer to the Web interface guide.

Light polymerisation instrument display

The display example shows the following:

Program labelled "Program 1"

Curing time: 25 Seconds

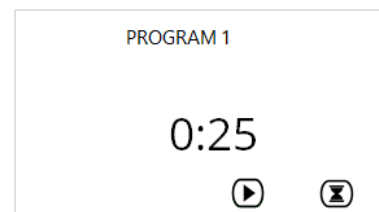

Operation

When the instrument is selected, the instrument table display will change to the instrument program in the active treatment. In this mode the curing timer can be adjusted using the arrow UP and DOWN keys on the instrument table. The dental light intensity and colour will change to the preset values. Select a different active instrument to change the dental light intensity and colour. The instrument is subsequently activated using the foot control or by pressing the button on the polymerization light and the countdown of the curing timer will start.

If selective display has been chosen, the instrument table display will only show the information that has been selected for the ongoing active treatment.

As standard, the polymerization light is supplied with one program with individual settings. You can switch between the programs by double-tapping the middle ring on the foot control.

If the polymerization light instrument has switch functions on the handpiece, please refer to regulations issued by the instrument manufacturer.

Manual adjustment of the curing light time

When the instrument is selected, the display will show the pre-programmed curing time. This can be changed by pressing on the up/down arrows of the instrument table display.

Syringe instrument

Heka G⁺ can be supplied with different syringes:

3-function syringe	Air (cold), water spray (cold) and combined spray (cold).
6-function syringe	Air(cold), water (cold) and combined spray (cold) as well as Air (warm), water (warm) and combined spray (warm).
7-function syringe	Air (cold), water spray (cold) and combined spray (cold) as well as Air (warm), water (warm) and combined spray (warm) and fiberoptic light.

We have chosen to describe the Unic syringe (3-function syringe) and will address other syringe types only in brief.

Available settings

Programs	No Programs
General settings	Turning on/off (applicable to 7-function syringes only). Standard: Double tap on the middle ring. Option: Double tap on the activation ring (Will give a delay).
Instrument light intensity	
Switching between programs	

Factory settings

None.

Operation

With the instrument selected, the syringe handpiece can be used to activate one of the following:

Air spray	Air key activated
Water spray	Water key activated
Combined spray	Air and water key activated

Water and air adjustment

Regulating cocks are installed under the syringe instrument for:

Regulating cock	Regulating of	Clockwise turning	Anti-clockwise turning
Blue	Spray air	Reduction	Increase
Green	Spray water	Reduction	Increase



Regarding use and operating times, please refer to the regulations issued by the instrument manufacturer.

Intraoral camera instrument

The functions and level of integration depends on the type of camera installed.

Available settings

Programs	1 individual program with individual name.
With general configuration of the following:	
Dental light intensity	From 0% to 100% (Possibility of adjusting brightness depends on the type of operating lamp).
Display	Full or selective display.
Switching between programs	Standard: Double tap on the middle ring. Option: Double tap on the activation ring (Will give a delay).

Factory settings

Individual configuration	Program 1
Program name	Camera
General configuration	
Dental light intensity	100% (not displayed)
Display	Normal display

The settings can be changed via the Web interface, - please refer to the Web interface guide.

Intraoral camera instrument display

The display example shows the following:

Program labelled "Program 1"

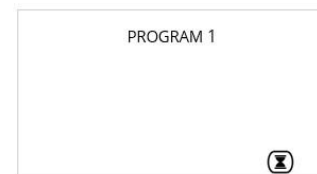

Operation

When the instrument is selected, the instrument table display will change to the instrument program in the active treatment and the fiberoptic light will switch on. Depending on configuration, the intraoral image will be displayed on the screen media (monitor or tablet).

If selective display has been chosen, the instrument table display will only show the information that has been selected for the ongoing active treatment. As standard, the intraoral camera is supplied with one program with individual settings.

For Acteon Sopro cameras

The image on the screen can be frozen by a short press on the activation ring on the foot control. Another press on the activation ring on the foot control will return the camera to normal mode.



Regarding use and operating times, please refer to the regulations issued by the instrument manufacturer.

Air Polisher instrument

Available settings

Programs	1 to 9 individual programs with individual names.
With individual configuration of the following: Spray:	no spray, water spray.
With general configuration of the following: Dental light intensity Display Switching between programs	From 0% to 100% (Possibility of adjusting brightness depends on the type of operating lamp). Full or selective display. Standard: Double tap on the middle ring. Option: Double tap on the activation ring (Will give a delay).

Factory settings

Individual configuration	Program 1
Program name	Air Polisher
Spray	water spray
General configuration	
Dental light intensity	100% (not displayed)
Display	Normal display

The settings can be changed via the Web interface, - please refer to the Web interface guide.

Air Polisher instrument display

The display example shows the following:

Program labelled "Program 1"

Water spray

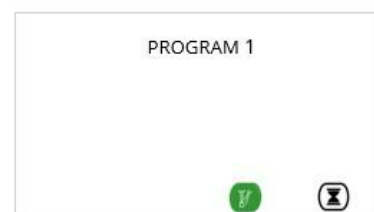

Preparing for the treatment/refilling the powder container

Remove the pressure from the container by selecting the instrument, de-selecting the water spray and activate the instrument.

Unscrew the lid from the container and fill the container with powder.

Screw the lid back on and ensure it is tight.

Enable water spray and the instrument is ready for treatment.

Operation

When the instrument is selected, the instrument table display will change to the instrument program in the active treatment. If the instrument is equipped with a fiberoptic light, this will be turned on automatically. In this mode you can change program settings. The instrument is subsequently activated using the foot control.

If selective display has been chosen, the instrument table display will only show the information that has been selected for the ongoing active treatment.

When the instrument is selected, the intensity can be adjusted using the foot control. The Air Polisher instrument can be configured with up to nine programs with individual settings. You can switch between the programs by double-tapping the middle ring on the foot control.



The button on the container bracket can be used to blow compressed air through the instrument hose to remove any blockage caused by residual powder.

Water and air adjustment

Regulating cocks are installed under the Air Polisher instrument for:

Regulating cock	Regulating of	Clockwise turning	Anti-clockwise turning
Blue	Spray air	Reduction	Increase
Green	Spray water	Reduction	Increase
Neutral	Forced air	Reduction	Increase

Increasing the air pressure increases the cleaning effect and reduces the polishing effect.

Increasing the water flow rate increases the polishing effect and reduces the cleaning effect.



Regarding use and operating times, please refer to the regulations issued by the instrument manufacturer.

Sterile water system

The sterile water system allows automatic supply of sterile fluid when the motor or ultrasonic scaler, depending on model, is activated.

The normal water/air spray function will be turned off at the same time.

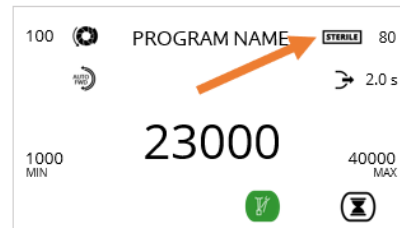

Available settings

Programs	One program
With individual configuration of the following:	
Sterile water flow:	Manual
Display:	STERILE Shown in the display when the sterile water system plug is plugged in.

Installation of sterile water system

1. Install the sterile water pump on the tray elevation.
2. Insert the bag holder in the adapter cavity of the pump.
3. Remove the black protective cap from the pump motor.
4. Check that the sterile tube set bag is usable and that the packaging has not been broken.
5. Install the pump wheel on the pump motor (see figure 1). Then install the safety cap on the pump motor axle.
6. Install the tube on the sterile bag. The blow flow control must be left completely open.
7. Install the surgical instrument and connect the tube to the external water duct of the instrument.
8. Apply tube clips on the instrument tube.
9. Connect the plug from the pump motor to the corresponding female socket on the rear of the instrument table.
10. The sterile water system is now ready for use.

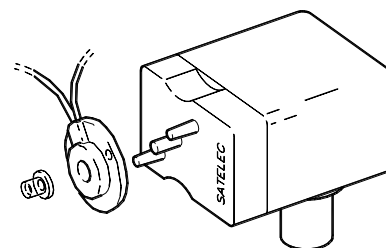

Select the instrument to be used with the sterile water system. If you want to move the sterile water system to another instrument, disconnect the plug for a second. After reconnecting the plug, the sterile water system will be associated with the first instrument selected.

Operation

The spray water and air valves for the instrument will be disengaged and the arrow UP and DOWN keys on the assistant side of the instrument table can be used to increase or decrease the pump speed and thereby the fluid flow.

Sterile water system activation

Press the activation ring on the foot controls to activate the sterile water system. The normal spray supply is interrupted and the pump motor will automatically supply sterile water by activating the motor using the foot controls.

Water/pump can be enabled or disabled using the middle ring on the foot control.

Normal water supply

The unit will return to normal mode when the pump is disconnected.

Water bottle systems

Options

Internal bottled water, 1 liter

External bottled water, 2 liters

External Bottle water
ON / OFF

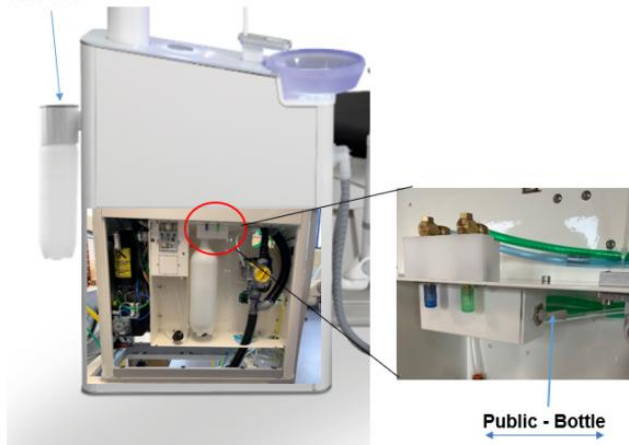

Operation

The switch on the bottled water system allows you to select between external supply (Public) or bottled water supply (Bottle).

Water treatment system

Options

Model: Metasys WEK

Function

The water treatment system is used for continual purification of water from the external water supply. The water treatment system automatically doses the necessary chemicals from an internal tank.

Operation and Warnings

The system can detect warnings/errors and an error message can be read under the menu in the instrument table display. Also refer to the manufacturer's guidelines. Also refer to the manufacturer's guidelines. Behind the Heka G⁺ service side, a control panel with the following identifications can be found:

3 See illustration	
3.1 Control lamp 1	Operational (green)
3.2 Control lamp 2	Error (red)
3.3 Control lamp 3	Disinfection indicator (yellow)
3.4 Alarm RESET key	

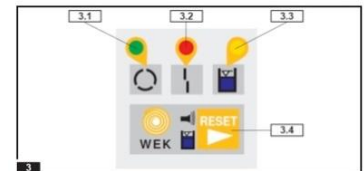

4 Start/test routine: If the green control signal

3.1 flashes: During the start process, WEK will perform an automatic test routine, in which the control lamp 1 3.1 will rapidly flash. In the event of an error, the device will not start; the error will be shown on the control component (see below). If the test is successful, the control lamp 1 will be constantly illuminated and the device is operational.

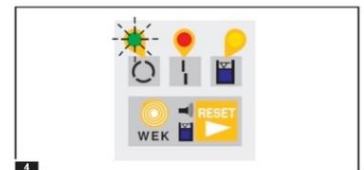

Mode	Cause	Remedial action
5 The green control signal 3.1 and the yellow control signal 3.3 will be illuminated and a signal tone will sound	The chemical sensor indicates that no disinfection of service water has been performed!	Change the chemical bottle (see page 10)! If the chemical bottle cannot be replaced immediately, the RESET key must be pressed to deactivate the constant signal tone. The device is still functional so that the dentist's work process is not interrupted. However, a shorter signal tone will sound at regular intervals. If the error message is due to an air bubble only, the error message will turn off by itself during the next attempt. But no disinfection will take place before the empty chemical bottle is replaced by a full one.



Mode	Cause	Remedial action	Consequence
6 The green control signal 3.1 is constantly illuminated while the red control signal 3.2 flashes and a signal tone sounds.	The level probe in the mixing tank is dirty, or no water is being supplied!	First check whether the main water tap or water supply is open! Clean or replace the mixing tank probe.	Close all valves and turn the pump off. The signal tone can be cancelled using the RESET key. When you have rectified the cause, WEK can only be activated again by turning it off and on.

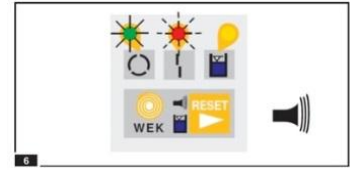

Mode	Cause	Remedial action	Consequence
The green control signal 3.1 and the red control signal 3.2 are illuminated and a signal tone sounds	Defect in the double membrane pump or overflow!	Clean the overflow probe. Check the double membrane pump and print card	Close all valves and turn the pump off. The signal tone can be cancelled using the RESET key. When you have rectified the cause.

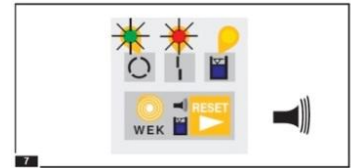

Cleaning

Please refer to the enclosed information from the manufacturer.

Under the Cleaning section of these operating instructions, there are cleaning guidelines that can be followed.

Timer

Available settings

Programs	1 to 9 individual programs with individual names.
With individual configuration of the following: Time periode	0 seconds to 9999 seconds.

Factory settings

Individual configuration	Program 1
Program name	Timer 10 sec.
Time period	10 seconds

The settings can be changed via the Web interface, - please refer to the Web interface guide.

Timer display

The display example shows the following:

Program labelled "K Silikone 30 sec."

The timer is set for 30 sec.

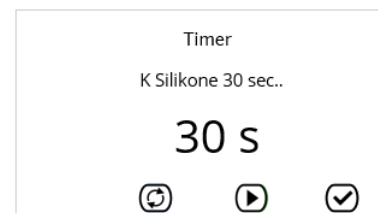

Operation

With the instruments placed in the holders, the instrument table display will change to normal mode, in which the timer (⌚) symbol in the lower right corner. Pressing this symbol will show you the menu, from which you can choose the timer program.

Pressing the icon will change the display to timer display. In this mode, you can select another program or manually change the selected timer setting as shown in the table below. You can change between the pre-programmed timers by double-tapping the middle ring on the foot control. The individual program times can be manually changed in active treatments by a short or long press on the arrow UP or DOWN keys. The timer is subsequently activated by pressing the arrow RIGHT key.

Arrow UP, instrument table	Change time, logarithmic increase.
Arrow DOWN, instrument table	Change time, logarithmic decrease.
Arrow LEFT, instrument table	Temporarily stops the time period
Arrow RIGHT, instrument table	Starts the time period.
Double tapping the middle ring	Switches between time programs

Please note that the manually adjusted time is not saved. If you would like to make changes to the pre-programmed timer programs, this must be done via the Web interface. After starting the timer (arrow RIGHT), the instrument table display will count down and three beeps will sound when the timer finishes the countdown.

Dental light

Available settings

In the treatment program settings for each instrument, you can select the brightness and light colour the dental light will emit until another instrument is selected.

EVA Operation lamp with CAN control: With an EVA dental light with CAN control it is possible to choose colour and light intensity depending on which instrument has been selected.

If choosing “Keep Operation Lamp Setting” in the Treatment menu, the lamp will switch to composite light when a curing light is selected and switch back to the previous setting when another instrument is selected. Intensity and light colour for normal dental light programs are changed on the light.

Alternative: If a colour is selected in the treatment menu, the dentist has to define the colour and intensity level for each program.

It is possible to enable/disable the sound in the EVA light in One Connect technician menu.

Heka ALYA dental light: The dental light can be set up as off, fully on and reduced intensity for each instrument program using One Connect.

Settings	Notes
0%	OFF
1-49%	Reduced brightness
50-100%	Max. brightness

Cuspidor, including glass filler and bowl

Available settings



Cuspidor position with/without safety	From -90 to +90, - total 180 degrees
Bowl flush time	0 to 20 seconds
Console top light colour	Optional
Bowl light colour	Optional
Bowl light pulsing colour	Pulsating light to guide the patient to spit in the bowl
Time period for glass filler	0 to 20 seconds

Factory settings



Settings	Notes
Cuspidor position*	-90 to 0 degrees, patient chair safety locked
Time period for bowl flush	5 seconds
Console top light	Blue
Bowl light colour	Blue
Bowl light pulsing colour	None
Time period for glass filling	5 seconds

*Heka G⁺ can be configured so that the patient chair is locked when the Cuspidor is turned over the patient.

Operation of glass filler and bowl on the instrument table

Instrument table	Notes
 Short press on touch key	A short press will fill the glass for the programmed period, followed by a bowl flush. The patient chair is moved to the rinsing position. To return to the previous position, "last position" can be activated using the joystick or patient chair arrows on the instrument table.
 Long press on the touch key	A long press will manually fill the glass while the key is activated.

Operation of glass and bowl on the top of the console

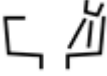
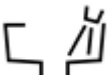
Assistant side		Notes
	Short press on touch key	A short press will fill the glass for the programmed period, followed by a bowl flush.
	Long press on the touch key	A long press will manually fill the glass while the key is activated.
	Short press on touch key	A short press will flush the bowl for the programmed period.
	Long press on the touch key	A long press will manually flush the bowl while the key is activated.

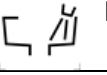
Patient side		Notes
	Press on touch key	Will manually fill the glass while the key is activated.
	Press on touch key	Will manually flush the bowl while the key is activated.

Warnings, top of console

Icon	Description	Notes
Patient chair, red icon	The patient chair is locked.	An instrument is active or the cuspidor is rotated out.
Red triangle	Warning, - see sub-menu by pressing the icon on the instrument table.	See detailed explanation further on.
Red padlock	The device is locked.	Locking of Heka G+ typically takes place in connection with cleaning and drying.

Spittoon valve

In connection with wet suction, the Heka G⁺ can be supplied with a cuspidor valve.

Available settings

Model: Metasys or Dürr.

Type: Manual or automatic

Operation of Metasys cuspidor valve

The Metasys spittoon valve will automatically open/close when needed in connection with treatments. If you wish to manually open the spittoon valve, the service cover must be opened and the activation button be pressed.

Operation of Dürr spittoon valve

The Dürr spittoon valve will automatically open/close as needed in connection with treatments. If you wish to manually open the spittoon valve, the service cover must be opened and the activation button be pressed.

Suction tube

Available settings

Number of locations	1 to 3, can be distributed between suction cannula and instruments (light polymerization lights, multifunction syringes or intraoral cameras.)
Location	On the telescopic arm on the unit console or patient chair
Options for suction cannula	Adjustable suction cannula, non-adjustable suction cannula
Suction hoses	Ribbed (flexible), smooth.
Suction cannula holder	Open and closed
Suction cannula top	Available in the 11 and 16 mm
Suction options	Selective, only the selected suction hose is active.
Suction tube cleaning	Manual or automatic
Suction flow	Medium volume suction system from 90 to 250 L/min.
Suction system	Dry (separation automation) or wet (spittoon valve)
Deactivation during use via foot switch (Ergo suction)	

Factory settings

Number of locations	2
Location	Telescopic arm, console
Options for suction cannula	Adjustable
Suction tubes	Ribbed
Suction cannula holder	2
Suction cannula top	XX mm
Suction tube cleaning	Manual or automatic

Suction

Operation of suction

When one or more suction cannulas are removed from the holder, the suction motor will automatically activate, and a vacuum is created.

Removal of suction cannula

The top of the suction cannula can be removed for cleaning and autoclaving. The O-ring on the suction cannula should be lubricated using silicone grease in connection with daily cleaning.



Removal of suction holders

The suction holder can be easily removed for cleaning.

Removal of filter for

On each suction tube, a filter is installed and this can be replaced/cleaned.



suction hoses

suction filter is easily removed for cleaning. Clean with a brush.

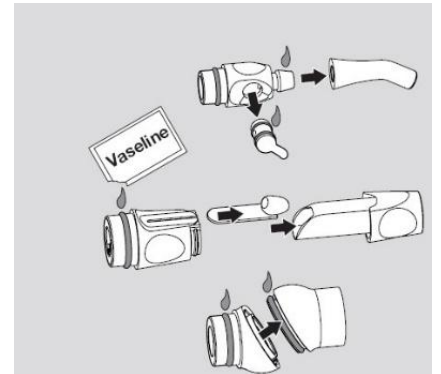

Adjustment of telescopic arm

The telescopic arm can be adjusted by loosening the two couplings X1 and X2 (works as friction brakes). The telescopic arm length can then be changed and locked using the two couplings.



Air/water separator

Available settings

Dürr or Metasys

Model Dürr air/water separator

Function

The air/water separator is used in connection with dry suction and separates the water from the vacuum air.

Operation

The air/water separator will automatically start when the suction system is activated in connection with treatment or suction hose cleaning.

Warnings

The system can detect warnings/errors, and these can be read under the menu in the instrument table display. Also refer to the manufacturer's guidelines. Behind the Heka S⁺ service cover, a control panel with the following identifications can be found:

Cleaning

Please refer to the enclosed information from the manufacturer. Under the Cleaning section of these operating instructions, there are brief cleaning guidelines that can be followed.

Model Metasys air/water separator

Function

The air/water separator is used in connection with dry suction and separates the water from the vacuum air.

Operation

The air/water separator will automatically start when the suction system is activated in connection with treatment or suction hose cleaning.

Warnings

The system can detect warnings/errors, and an error message can be read under the menu in the instrument table display. Also refer to the manufacturer's guidelines. Also refer to the manufacturer's guidelines. Behind the Heka S⁺ service cover, a control panel with the following identifications can be found:

Cleaning

Please refer to the enclosed information from the manufacturer. Under the Cleaning section of these operating instructions, there are cleaning guidelines that can be followed.

Dürr amalgam separator

Function

The amalgam separator is used in connection with dry suction and separates water from the vacuum air and collects amalgam in a container.

Operation

The amalgam separator will automatically start when the suction system is activated in connection with treatment or suction hose cleaning.

Cleaning

Please refer to the enclosed information from the manufacturer.

Under the Cleaning section of these operating instructions, there are cleaning guidelines that can be followed.

Warnings

The system can detect warnings/errors and an error message can be read under the menu in the instrument table display. Also refer to the manufacturer's guidelines.

When the amalgam container in the separator is 90% full, a visual and acoustic alarm will appear in the separator keyboard placed in the device.

The following is from Dürr's instructions:

- 1 Display module
- 2 RED indicator
- 3 GREEN indicator
- 4 Acoustic signal
- 5 Reset / service key
- 6 YELLOW indicator

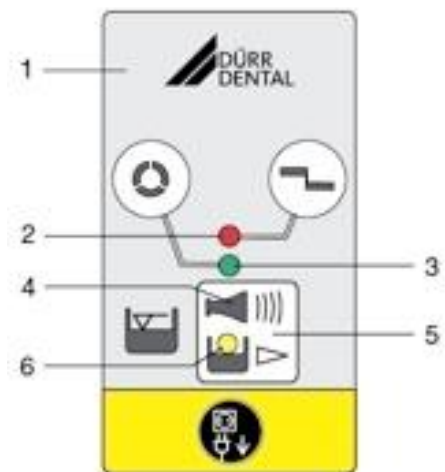

Status	Identification	Description
Operational	Green indicator is illuminated	
In the event of the amalgam collection container being 95% full	Yellow indicator is illuminated, green indicator is illuminated, and an acoustic signal is emitted	<p>At 95% full, the acoustic signal can be turned off by pressing the reset button.</p> <p>The device is subsequently operational again.</p> <p>The yellow indicator is illuminated as a reminder of the required replacement of the amalgam collection container.</p> <p>After restarting using the main switch, the level display will resume.</p> <p>We recommend replacing the amalgam collection container when the filling level is 95%.</p>
In the event of the amalgam collection container being 100% full	Yellow indicator is illuminated red indicator flashes An acoustic signal is emitted	<p>At 100% full, the acoustic signal can no longer be interrupted by pressing the reset button.</p> <p>The collection container must be replaced.</p> <p>Safety equipment must be used to avoid infections (e.g. leak-proof gloves, safety goggles, mouth and nose protection)</p> <p>Only when the amalgam collection container has been replaced will the amalgam separator be "operational" again</p>
Amalgam collection container not inserted	Red indicator flashes	<p>An acoustic signal sounds</p> <p>The acoustic signal can be interrupted with a short press on the reset button.</p> <p>Turn the device off.</p> <p>Insert the collection container.</p> <p>Turn the device on. Green indicator illuminates "operational"</p> <p>If this error message appears when the collection container is inserted, there is a technical fault - contact the technician.</p>

Metasys amalgam separator

Function

The amalgam separator is used in connection with dry suction and separates water from the vacuum air and also collects amalgam in the liquid.

Operation

The amalgam separator will automatically start when the suction system is activated in connection with treatment or suction tube cleaning.

Cleaning

Please refer to the enclosed information from the manufacturer.

Under the Cleaning section of these operating instructions, there are cleaning guidelines that can be followed.

Warnings

The system can detect warnings/errors and an error message can be read under the menu in the instrument table display. Also refer to the manufacturer's guidelines.

When the amalgam container in the separator is 90% full, a visual and acoustic alarm will appear in the separator keyboard placed in the device.

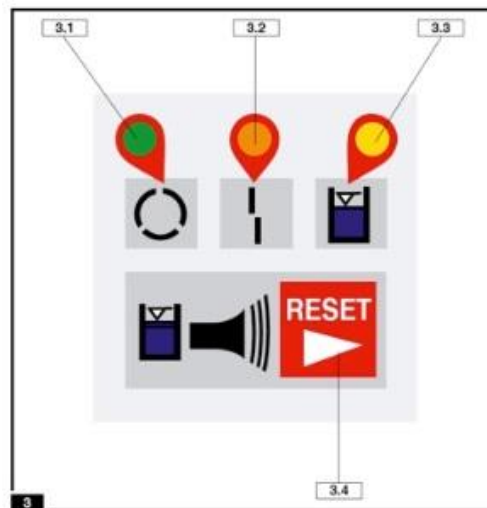

The following is from Metasys' instructions:

Status	Identification	Description
3.1 Control lamp 1	Operational, illuminates green	Mains power connected
3.2 Control lamp 2	Centrifuge error, flashes red: error!	Disconnect the main switch several times and turn on again after a short break. If the control lamp illuminates again after a short period, you need to contact your service technician.
3.3 Control lamp 3	The container level indicator illuminates yellow and buzzes	The signal tone can be disconnected using RESET: 95% of the collection container is full: It is recommended that the collection container be replaced; however, work may continue until the indicator shows 100%. The control lamps will continue to be illuminated as a reminder. The buzzer signal tone will sound again each time the main switch is connected.
3.3 Control lamp 3 and buzzer,	The container level indicator illuminates yellow and buzzes, the signal tone cannot be disabled using RESET	100% of the collection container is full; The collection container must be replaced! It is not possible to continue working, the suction power valve will block.
3.4 Alarm RESET button	By pressing the red button, 95% of the buzzer can be disconnected when the container is being filled.	

Locking of Heka G⁺ in connection with cleaning

Available settings

Automatic unlock	Automatic or manual
Time period	0 to 9 minutes

Factory settings

Automatic unlock	Automation
Time period	2 minutes

The settings can be changed via the Web interface, - please refer to the Web interface guide.

Display for locking of Heka G⁺

The display example shows the following:

The unit will unlock in 1:38 minutes

Locked



Operation

The Heka G⁺ keyboard and display can be deactivated in connection with cleaning and disinfection as follows:

Location	Description
Instrument table - locking	Activate the patient chair symbol and subsequently activate the arrow UP and RIGHT keys simultaneously.
Instrument table - manual unlock	Activate the patient chair symbol and subsequently activate the arrow UP and RIGHT keys simultaneously for at least two seconds.
Console top - locking	Activate the patient chair symbol and subsequently activate the arrow UP and RIGHT keys simultaneously.
Console top - manual unlock	Activate the patient chair symbol and subsequently activate the arrow UP and RIGHT keys simultaneously for at least two seconds.
In the event of automatic unlock	After activating the locking function, the timer will count down and Heka G ⁺ will automatically unlock after the end of the time period.

Cleaning & disinfection

This section contains information about how to clean and disinfect the Heka Dental Heka G⁺ equipment. For detailed information about cleaning, disinfection and sterilisation of OEM equipment and instruments purchased for use with Heka G⁺, please refer to the OEM documentation.

The Center for Disease Control and Prevention (CDC) recommends the use of an EPA-registered chemical antibacterial hospital disinfectant, intended for use on tuberculocidal activity surfaces contaminated by patient materials.

In accordance with these guidelines, we recommend disinfection between patients. Dürr FD333, Sani-Cloth AF3 or similar may be used. It is important to follow the manufacturer's instructions in order to ensure effective disinfection.

Cleaning & Disinfection of clinical contact surfaces

The following provides a list of external clinical contact surfaces:

- Console
- Instrument arm
- Instrument holders
- Telescopic suction arm
- Fountain
- Instrument table
- Instrument & Suction tubes
- Suction tube holder
- Foot controls
- Instrument tray
- Instrument display

External surfaces on Heka G⁺ must be cleaned first and subsequently disinfected.

First, CLEANING

Wipe the external surfaces of the Heka G⁺ using a soft cloth dampened with a mild detergent or disinfectant solution at the start and end of each working day and if visible contamination is observed. Caution - avoid running water and water sprays during cleaning of the device surfaces.

Then, DISINFECTION

After cleaning, disinfect between each patient using Dürr FD 300 or Sani-Cloth AF3. It is important to follow the manufacturer's instructions in order to ensure effective disinfection.

Cleaning & Disinfection of external surfaces

CLEANING

Wipe using a soft cloth dampened with a mild detergent or disinfectant solution at the start and end of each working day. Caution - avoid running water and water sprays during cleaning of the device surfaces.

DISINFECTION

Disinfect between patients using Dürr FD333 or Sani-Cloth AF3. Follow the manufacturer's instructions to ensure effective disinfection.

Precautions:



Do not use the detergents included in the following list as these could damage the device components:

- Wax polishing agents
- Alcohol
- Acetone
- Tetrachloroethylene
- Trichloroethylene
- Powder cleaning
- Disinfectants containing halogens
- Sulphates



Attaching and removing the handle

Turn the handle anti-clockwise and remove for cleaning.
Turn the handle clockwise to install it again.

Lamp head and dish

Please refer to the instructions in the Faro lamp manual.

Attaching and removing the cuspidor glass bowl

The glass bowl can be removed for cleaning.
Remove the "mushroom" from the drains.

Turn the bowl anti-clockwise and lift it off for cleaning.



The bowl is re-installed by following the instructions in the opposite order

**The glass bowl must be cleaned at a temperature of max. 65°C.
An optional clear glass bowl can be cleaned at temperatures up to 93°C.**

The chair will be blocked as long as the Cuspidor is facing the patient.
Rotate it towards the console end to allow chair movement again.

Cleaning & Disinfection of the patient chair upholstery

First, CLEANING

Wipe using a soft cloth dampened with a mild detergent or disinfectant solution at the start and end of each working day.

If visible contamination is observed, Dürr FD366 upholstery cleaner or cleaning products such as Fantastik® and Formula 409® may be used. Wash with clean water to remove soap residue and allow the upholstery to air dry. Caution - avoid running water and water sprays during cleaning of the device surfaces.

Then, DISINFECTION

Disinfect between patients using Dürr FD360 or Sani-Cloth AF3. Follow the manufacturer's instructions to ensure effective disinfection.

Suction hose cleaning system

If Heka G⁺ has been supplied with a suction cleaning system, the following options are available.

Available settings

Ordinary daily cleaning:	Using detergent or water
During patient treatment:	Using detergent or water

Factory settings

The suction cleaning system has been configured for use with METASYS (Disinfection and Cleaning H1) detergent

Operation

Suction hose positioning	Press the C key on the top of the console	Description
In Holder: Automatic cleaning can always be stopped by lifting one of the suction hoses.	Short press	Suction tube cleaning takes place using detergent/water alternately during the pre-configured period, see display 1 below*
In Holder: Automatic cleaning can always be stopped by lifting one of the suction hoses.	Long press	Suction tube cleaning takes place using water during the pre-configured period, see display 1 below*
Lifted from holder – during patient treatment	Short press	Suction tube cleaning using detergent/water during the pre-configured period
Lifted from holder – during patient treatment	Long press	Suction tube cleaning using water during the pre-configured period

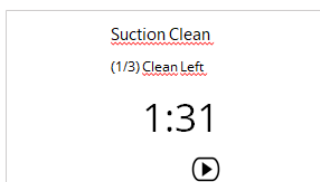

In connection with daily automatic cleaning of suction tubes (located in the holder), the remaining time will be shown in the instrument table display. Display 1.



When cleaning has been completed, the cleaning will stop and the unit will issue a brief acoustic signal and the instrument table display will show "Clean OK".

A short press on the left arrow will cause the unit to return to normal mode.

Error display

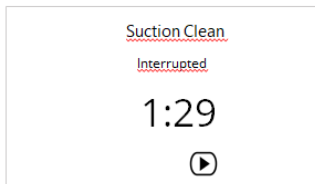

The following displays are shown in the event that the suction tube cleaning program did not finish correctly.

The error could be due to the device having been turned off, one or more suction hoses having been removed from the holder or the operator having interrupted the suction cleaning process.

Fluid refill

The cleaning system has been configured for use with METASYS (Disinfection and Cleaning H1) detergent.

Regularly check that there is detergent in the internal bag under the service hatch. The bag must be replaced as needed.

Be aware:

Detergent consumption is lower during manual cleaning than during automatic cleaning.

Manual cleaning stops when all suction cannula are placed in the suction holder again.

The cleaning system has been configured for use with METASYS (Disinfection and Cleaning H1) detergent (1 litre).

Instrument flush using water

To ensure a fresh water supply, Heka G⁺ can be supplied with automatic water flushing of instruments.

Available settings

Programs	1 to 3 individual programs with individual times/names.
With individual configuration of the following: During rinsing period	0 to 9 minutes

Factory settings

Individual configuration	Program 1	Program 2
Program name	Instr. flush 3 min.	Instr. flush 6 min.
During rinsing period	3 minutes	6 minutes

The settings can be changed via the Web interface, - please refer to the Web interface guide.

Operation

Remove the hand- and angle pieces as well as the multiflex coupling. The instrument flushing bowl must be placed in the cuspidor with all waterborne instruments inserted, including waterborne instruments on the telescopic head. The instrument table display will automatically change to "Instrument flush".

If several instrument flush programs have been programmed, you can change between these using the arrow UP or DOWN keys on the instrument table. Press the arrow RIGHT key on the assistant side of the instrument table to start the instrument flush.

The water spray valves will be engaged on for all selected instruments and the instrument table display will count down from the selected time.

When the flushing time has elapsed, the water spray valves will be disengaged, the device will issue a brief acoustic signal and the instrument table display will show "Flush OK".

By default the unit will enter standby mode, where the main valves are OFF. To return to normal mode you must press arrow right and up simultaneously.

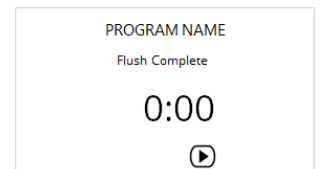
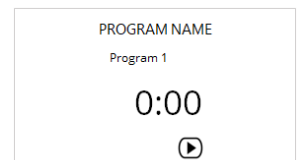

NOTE: The syringes do not have a water spray valve and will start flushing as soon as they are placed in the instrument flushing bowl, they will continue to flush until removed from the bowl again and the button on the syringe is released.

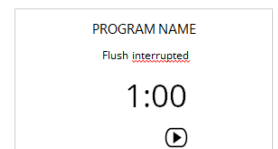

Error display

The following displays are shown in the event of instrument flushing not finishing correctly. The error could be due to the device having been turned off, an instrument having been returned or the operator having interrupted the instrument flushing. In order to remove the error message, either perform a correct instrument flush or return all instruments to the holder.

Maintenance

Removal of the instrument supports

The instrument holders for the instruments can be easily removed for cleaning.

Removal is performed by pulling the holders out from the instrument table.



See Cleaning and disinfection.

Maintenance of the equipment must be an integral part of the clinic routine!

Instruments	O-rings for instruments must be checked and, if necessary, replaced. O-rings must be lubricated using silicone grease.
Suction hoses	O-rings for suction hoses must be checked and, if necessary, replaced. O-rings must be lubricated using silicone grease.
Cuspidor	The Cuspidor glass bowl can be washed in a dishwasher (max. 65°C) The optional clear glass bowl can be autoclaved at 93°C
Foot control	It is important to ensure that the foot controls are stable on the floor. Over time, the rubber feet below the foot controls may become lubricated from floor polish, soap, etc., and the foot controls may start to slide on the floor. The rubber feet can be cleaned using benzine or another degreaser.
Water supply	There may be national or international requirements in place that say that instruments, etc., must be rinsed with water after each patient and/or after a period of inactivity. This can be performed using automatic instrument flushing.

Service

In connection with any service carried out on the Heka G⁺, a message may be shown in the instrument display after start-up. The message can be removed through a pressing the arrow RIGHT key

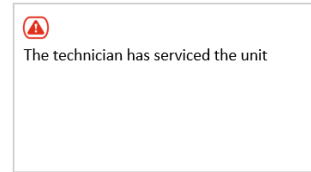

Annual service

To ensure that Heka G⁺ continues to have high reliability and works in accordance with the specifications, the equipment must be checked by an authorised service technician. Furthermore, this is a prerequisite for the factory warranty. The annual service date is generated automatically based on the equipment installation date.

When the annual service date is approaching, the instrument table display will start showing the remaining number of days during start-up (starting 28 days prior to the annual service).

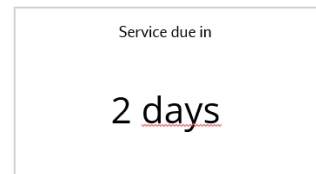

The message will be shown for 5 seconds and goes away automatically.

If the annual service date is missed, the number of overdue days will flash for 10 seconds and can be removed only by activating the RIGHT arrow key on the instrument table.

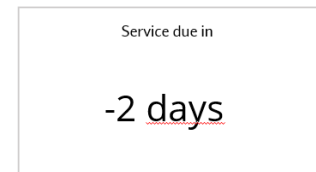

After the annual service has been completed, the following information will be shown in the instrument table display and can be removed by activating the RIGHT arrow key on the instrument table.

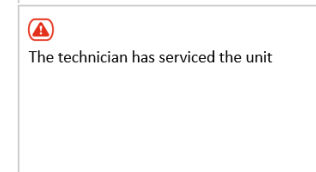

Annual service checklist

Unit	Checked	Adjusted/Programmed	Replaced	Product no.	Rep.
Console	Check software of Software				
	Unit earthing				
	Water regulation kit			* 907	
	Filter insert for water			* 900	
	Filter insert for air			* 901	
	Valve seating gasket (Main water valve)			* ft-2141-15	
	Flat ring gasket (Main water valve)			* ft-2274	
	Water pressure 2 bar				
	Air pressure 4.5 bar				
	Main solenoid valves close tightly			f-043	
Unit for superficial damage			Lak. A-499 A-499-1		
Suction, suction cleaning + telescopic arm	Suction tube 11mm grey ribbed			** 2m/ ***3m ft-2154-15	
	Suction tube 16 mm grey ribbed			** 2m/ ***3m ft-2155-15	
	Return air tube, red			** 4.3m/ ***6.3m a-118	
	Cleaning syringe			**/*** 2 x f-548	
	Suction angle with tube, long			**/*** 2 x f-522	
	Top, large suction, 17 mm NY			* f-688-1	
	Top, small suction NY			* f-686-1	
	Middle piece small Asp			**/*** fc-0684-01	
	Bottom small aspiration			**/*** fc-0682-01	
	Middle piece big aspiration			**/*** fc-0685-01	
	Bottom big aspiration			**/*** fc-0683-01	
	O-ring 14 x 1 (for middle piece suction)			**/*** 2 x f-681	
	O-ring filter			**/*** 2 x f-518	
	Top large suction cock (11 mm)			* ft-2267	
	O-ring filter			* 4 x f-518	
	Suction filter, long			* 2 x f-523-1	
	Clean the suction manifold				
	Dürr membrane for site selection valve			* 2 x 7560-500-22	
	Dürr site selection valves			2 x 7560-500-77	
	Suction holder activation				
	Adjust the telescopic arm				
	O-ring 3.15 x 1.80 (suction holder)			* 8 x ft-0020-15	
	telescope function				
	Valve seating gasket (suction cleaning valves)			**/*** 2 x ft-2140-15	
	O-ring 12.5 x 1.1 FKM (suction cleaning valves)			**/*** 2 x ft-0033-15	
	Non-return valve (internally in the suction cleaning block)			**/*** 2 x ft-2174-15	
	Metasys/Dürr amalgam separator MST1		cf. manufacturer's instructions		
Metasys WEK/WEK light		cf. manufacturer's instructions Remember annual service!!			
Cuspidor valve					
Spittoon	O-rings 21X4.5 (below bowl)			**** ft-0027-15	
	Mushroom filter			**** fc-0478	
	Valve seating gasket (Cup and bowl valve)			**** 2 x ft-2141-15	
	Flat ring gasket (Cup and bowl valve)			**** 2 x ft-0032-15	
	Cup and bowl valves close tightly			a-279	
	Flow times on cup and bowl				
	Flow strength on cup and bowl				
Arm					
Brake screws for arm					
Springs in arm					

	Unit	Checked	Adjusted/Programmed	Replaced	Product no.	Rep.
	Foot control					
	Functions					
	Curing light					
	Function					
	Exposure time					
Micro motor	Valve seating gasket (water valve)				* ft-2140-15	
	O-ring 12.5 x 1.1 FKM (water valve)				* ft-0033-15	
	O-ring 2.35 x 1 (adjusting needle, water)				* ft-2153-15	
	All 3 valves close tightly					
	Pre-selection of speeds and spray					
	Cooling air min. 10 l/minute					
	Spray water and air volume					
	Fibre light					
	Reversing (start – spray)					
	O-ring (Bien air)				* 6 x 011.35.28	
	Clean spray ducts					
Turbine	Valve seating gasket (water valve)				* ft-2140-15	
	O-ring 12.5 x 1.1 FKM (water valve)				* ft-0033-15	
	O-ring 2.35 x 1 (adjusting needle, water)				* ft-2153-15	
	All 3 valves close tightly					
	Spray pre-selection					
	Turbine forced pressure in accordance with manufacturer's regulations					
	Spray water and air volume					
	Return air pressure max. 0.3 bar					
	O-rings					
	Clean spray ducts					
	Fibre light					
Suction in return air container (console)						
Tooth cleaner	Valve seating gasket (water valve)				* ft-2140-15	
	O-ring 12.5 x 1.1 FKM (water valve)				* ft-0033-15	
	O-ring 2.35 x 1 (adjusting needle, water)				* ft-2153-15	
	Spray water valve closes tightly					
	Strength and spray pre-selection					
	Spray water volume					
	Fibre light (option)					
	Clean spray ducts					
	O-ring					
Syringe	O-ring 2.35 x 1 (adjusting needle, water)				* ft-2153-15	
	Function water + air valves					
	Valves close tightly					
	Spray water and air volume					
	Warm water + air (option)					
	Fibre light (option)					
	Clean spray syringes					
Extra equipment	Quick-coupling water					
	Quick-coupling Air					
	Quick-coupling suction					
	Water heater					
	230V plug					
	Bottled water					
	Sterile water					
Instrument flush						









Chair	Lubricate the spindle on the motors and movable parts				ft-2020-15	
	Check that the axle is securely attached to the back					
	Check/adjust lateral play in the back with metal washers				Ft-1303-15	
	Manual operation, including end stop and adjustment					
	Program Operation					
	Lamp					

Printed and electronic information

The information is delivered with the equipment and also available to authorised Heka Dental service technicians.

Please contact our technical department for further information or an authorised Heka Dental dealer.

Heka Dental A/S, Litauen alle 4, DK-2630 Taastrup.
Tel.: +45 43320990, Fax: +45 43320980, heka-dental.dk

	Please refer to the enclosed OEM instructions for cleaning / (in the maintenance section)	Motorised instrument with fibre optics, including motor tube
	Please refer to the enclosed OEM instructions for cleaning / (in the maintenance section)	Ultrasonic scaler
	Please refer to the enclosed OEM instructions for cleaning / (in the maintenance section)	Light polymerisation lamp
	Please refer to the enclosed OEM instructions for cleaning / (in the maintenance section)	3-7 function syringe
	Please refer to the enclosed OEM instructions for cleaning / (in the maintenance section)	Intraoral camera
	Please refer to the enclosed OEM instructions for cleaning / (in the maintenance section)	Water treatment system
	Please refer to the enclosed OEM instructions for cleaning / (in the maintenance section)	Separator
	Please refer to the enclosed OEM instructions for cleaning / (in the maintenance section)	Amalgam separator

IT requirements

The following section describes the minimum IT requirements for the Operator of the Unit with regards to the web interface and general software security.

To access Heka One Connect to configure the Unit it is required to have a PC with either ethernet- or wifi network capabilities and a browser with JavaScript enabled (the most popular browsers have it enabled by default, e.g. Chrome, Firefox, Edge). The following connection setups are possible:

1. Ethernet: Connect the Unit to a network via ethernet. The PC used to configure the Unit must be connected to the same network.
2. Wifi: Connect the Unit to a network via Wifi. To set up the Wifi connection for the first time the Unit must first be configured using either Ethernet or Ad hoc. The PC used to configure the Unit must be connected to the same network.
3. Ad hoc: Functionality is reserved for use by a Heka Certified Technician. Can be used to set up Wifi connection if Ethernet connection is not possible.

NOTE: If the Unit is configured for the first time via Ethernet then the network must have a DHCP server (this is standard practice on business networks). If the network is not using DHCP however, then Ad hoc is necessary to configure the static IP settings.

Security

To ensure effectiveness and expected performance of the Unit only authorized personnel shall be allowed to configure the Unit. The Operator must therefore take the following security precautions:

1. Physical access: Only a Heka Certified Technician are allowed to physically open and access the internals of the Unit.
2. Web access: The network which the Unit is connected to and the PCs connected to the network must be secured against unauthorized access according to best IT security practice. Specific security measures are relative to the operating IT environment, but it is always recommended to at least use strong passwords for access to network connected PCs and a strong password and encryption protocol for Wifi.

If unauthorized personnel gains Physical access to the Unit they can in the worst-case make it inoperable which requires complete replacement of the hardware components by a Heka Certified Technician.

If unauthorized personnel gains Web access to the Unit they may in the worst-case configure the Unit so it does not work as expected, and/or prevent future configuration via the web interface until their access is removed.

Personally Identifiable Information

The Unit does not require or use any Personally Identifiable Information, but it is possible for the Operator to enter Personally Identifiable Information into the Unit (e.g. naming of dentist or program in the web interface). *Do not enter Personally Identifiable Information into the Unit.*

Heka One Connect WEB interface

The WEB interface is used to make changes to profiles, treatments or instrument settings.

The unit must be connected to a network for the user to login and make adjustments.

The IP address of the unit can be found by pressing the “i” icon on the instrument table display, enter this into the address bar of a browser on a computer that is on the same network and press enter.

When you enter Heka One Connect using your browser, you will see the following page:

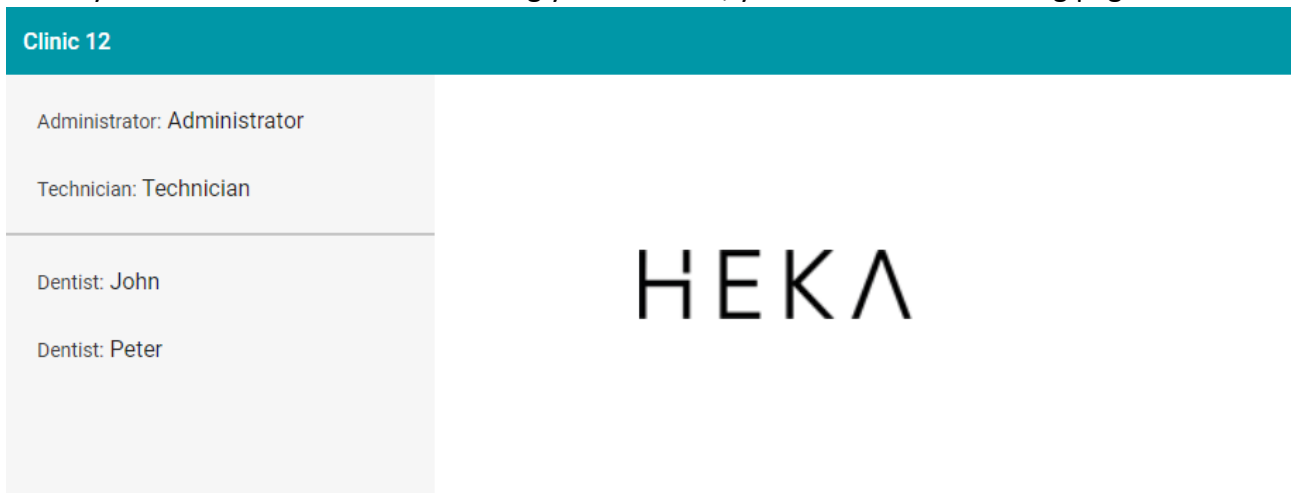

Select your profile and enter your password.

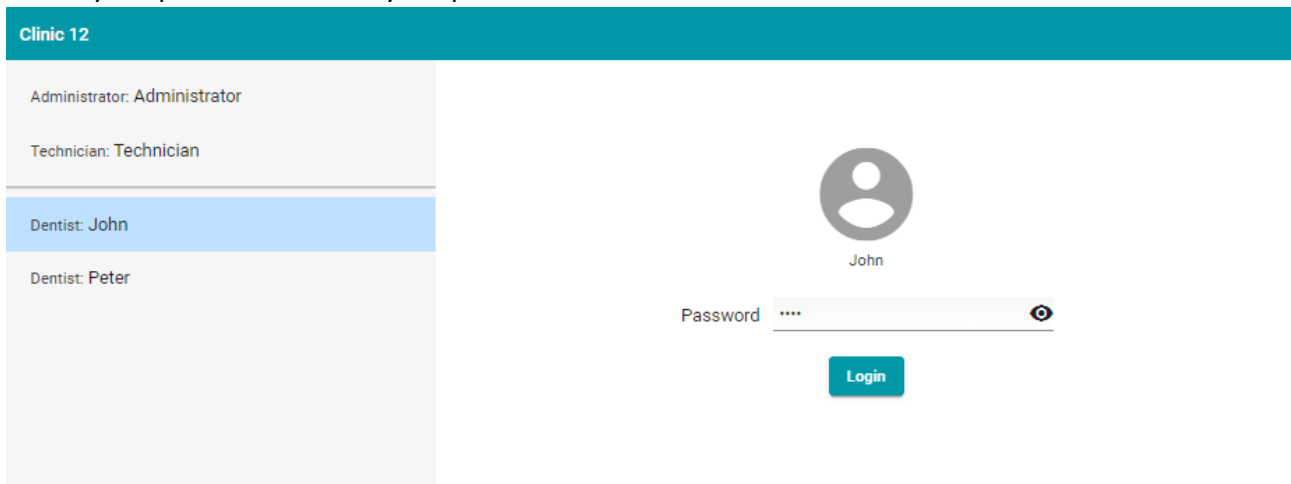

For details on Heka One Connect please see the **KA-9020 Programming Manual**, which is available on www.heka-dental.com under downloads.

Technical guidelines - only for authorised technicians

Technical data

Voltage	230V ~/115V ~
Frequency	50Hz/60Hz
Power consumption	5 A/10 A
Protective class	Type B applied parts
Classification	Class I

Fuses

Power board

Fuses	Type	Function
F1	F10A 125VAC SMF	44Vac
F2	F10A 125VAC SMF	24Vac
F6	F 2A 125VAC SMF	24Vac for Water treatment system (decontamination)
F7	F10A 125VAC SMF	24Vac for 7F syringe
F8	F 5A 125VAC SMF	24Vac for amalgam separator
F9	T5,0A H250VAC 5x20mm	Main Fuse (230Vac primary)
F10	T2,5A H250VAC 5x20mm	Trafo Fuse (230Vac primary)
F9	T10,0A H250VAC 5x20mm	Main Fuse (115Vac primary)
F10	T4,0A H250VAC 5x20mm	Transformer Fuse (115Vac primary)
Backside		
F3	F10A 125VAC SMF	34Vdc Logic
F4	F 4A 125VAC SMF	34Vdc Logic
F5	F 5A 125VAC SMF	24V
Inline Fuse		
F11	F10,0A H250VAC 5x20mm	Inline Fuse main
F12	F10A H250VAC 5x20mm	Inline Fuse f. sec. 44V
F13	T2.5A H250VAC 5x20mm	Dental light relay PCB

Console Controller board

Fuses	Type	Function
F500	F750mA 125VAC SMF	5Vdc for foot control
F1800	F2A 125VAC SMF	24Vdc for water decontamination system
F2200	F10A 125VAC SMF	34Vdc for Motor Power

Service and maintenance

No parts of the Dental unit should be service or maintained while in use with a PATIENT!

Service and maintenance

No parts of the Dental unit should be serviced, or maintained while in use with a PATIENT!

Installation requirements

For positioning of the Heka G⁺, please refer to the ground plan in the installation manual.

1. 230 Volt/115 Volt +/- 10%, 50/60 Hz, with earth. Branch fuse 10A/20A.
2. Water, supply pressure 2-6 bar (30-90 psi). Ball valve with R 3/8" internal thread.
Flow rate <-4 l/min. (max. consumption in the entire range).
Water quality: <- 8 dH (1 dH = 20 mg Ca/3 l water)
Top 5 cm above the floor.
3. Air, supply pressure 4.5 - 6 bar (65-88 psi). Ball valve with R 3/8" internal thread.
Flow rate <- 55 l/min. (max. consumption in the entire range).
Air humidity > 20 C at atp.
The air must be dry and free of oil. Max. 0.5 mg/m³
Particulate contamination limit must not exceed 100 ppm/m³ for 1 um to 5 um particle size.
Top 5 cm above the floor
4. Outlet, Ø 32 mm exterior, PVC pipe. Top: 5 cm above the floor.
Capacity: min. 10 l/min.
5. Suction, Ø 32 mm exterior, PVC pipe. Top: 5 cm above the floor. (DN40)
Vacuum: >- 150 mbar, Flow rate >- 550 l/min.
6. Control cable for suction motor, 2 x 1.5 mm². Free end 50 cm above the floor.
7. Control cable for assistant call, 2 x 1.5 mm². Free end 50 cm above the floor.
8. Any cables for x-ray equipment. Cable type/quantity depends on the make. Free end minimum 50 cm above the floor.
9. Place for installation of the console should be concrete, ceramic tile or other nonflammable material.
10. Temperature and humidity:
During operation: +10° C to +35° C, non-condensing air humidity from 20-75%, pressure 800 hPa - 1060 hPa.
Storage/transport condition: 10° C to +40° C, non-condensing air humidity from 50-80%, pressure 500 hPa - 1060 hPa.

230V/115V output for chair, lamp and extra equipment. They are all parallel connected and the total load must not exceed 5A/1150 W/10A/2300 W. All outputs have a T5.0A/T10.0A fuse.

Warning! To avoid electric shock, the Heka G⁺ must only be connected to a mains supply with protective earth.

Classification of equipment



Please refer to the enclosed OEM documentation for more information about OEM Equipment Classification

Dental Delivery System Method of operation Protection against water	Class IIA All type B applied parts patient parts comply with IEC/EN60601-1. Continuous operation with intermittent load. IP20
Patient Chair⁺	Class I, type B Applied parts for chair: Upholstery Armrests Footrest
Multifunctional syringe Intermittent use Protection against water	type B applied parts 10sec. ON / 20sec. OFF. IP20
Light polymerization lamp Intermittent use Protection against water	type BF. 10sec. ON / 40sec. OFF. IP20
Ultrasonic scaler Operation with water Operation without water Protection against water	type B applied parts 6 sec. ON / 3 sec. OFF for a maximum of 4 min. with normal water supply from the unit. (1-5 bar) Intermittent use; 2 sec. ON / 18 sec. OFF for a maximum of 10 min. IP20
Micro motor Function in compliance with CEI 34-1 type S Air cooling flowrate Protection against water	Class IIA, type S3 type B applied parts 3A for 60 sec. / 5A for 10 sec. Must be cooled down for 3 min. in the event of operation with air or for 20 min. in the event of operation without air. 10 l/min. IP20
Operating lamp Continuous operation Protection against water	Class I No requirements for operating/inactive time. IP20
Foot control Continuous operation: Protection against water	Class 1, accessible by screw connector No requirements for operating/inactive time. IP21

Compliance with regulatory standards

The device has been tested to comply with the applicable standards. The full text of the EU declaration of conformity is available upon request. Contact your Heka distributor.

Wireless foot controls, technical specifications

RF technology	Bluetooth
Battery	Li-ion Battery, DM355Y.388, 3.6V 2350mAh/8.5Wh
Battery charging	A fully charged battery can last up to 3 months

When the Foot Controller is connected to a charger and charging, a LED will indicate the charging level:

Green	Battery is fully charged
Red	Battery is charging.
Red flashing	Battery fault

In case of low battery, the Foot Controller can still be used if it is connected to the unit via the Foot Controller Cable.

The included Foot Control Charger is part of this Medical Electrical Equipment:

Brand: Emerson Network Power/Artesyn DCH3-050EU-0006

Specification: 100-240 VAC 120 mA, 5V=500 mA

Monitor

Monitor Power supply included:

Brand: Adaptor Technology Co. Ltd. ATM065T-P240

Specification: 100-240 VAC 50-60Hz 1.6 – 0,7A, DC 24V 2.71A

Hydraulic diagram

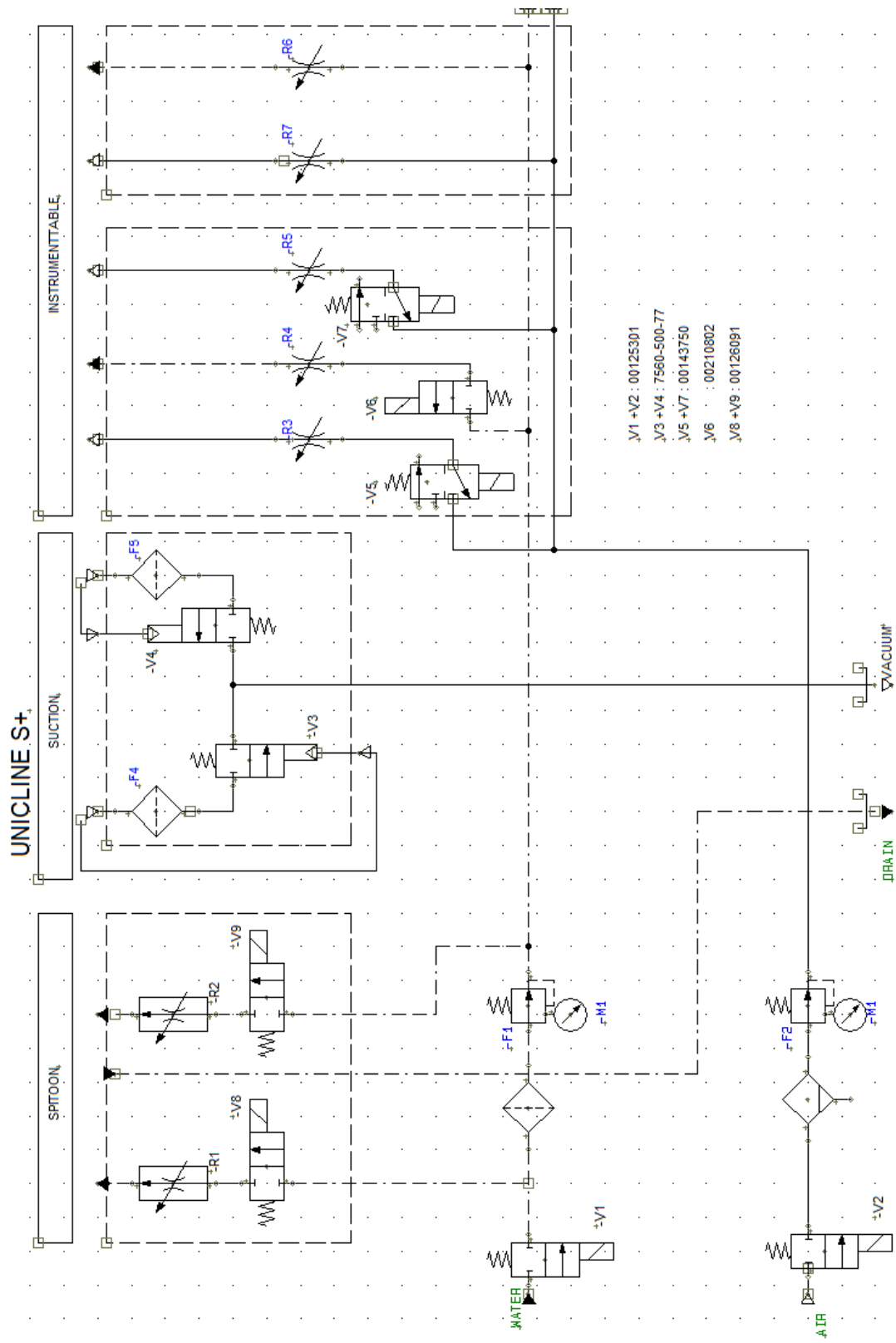

Special conditions in connection with connected Heka G⁺ and Heka Patient Chair

Conditions that affect the chair and unit:

- When an instrument is off holder, the chair will locked and the position cannot be changed before all instruments have been returned to their place. (It is possible to select from the menu that the chair will lock only when the instrument is activated).
- When the patient is to flush, press the symbol  "RINSE position" on the instrument table. The glass will fill and the chair will automatically move to RINSE position.
- For continued treatment, you can select the Last Position program via ether joystick or keyboards.

Precaution: New positions must be added to the chair's four program spaces for fixed positions. This is done by manually moving the chair (through a long press in one of the joystick directions) to the desired position, pressing the programming button (under the seat) and pressing the joystick in the direction that the position is to be saved.

Blocking of patient chair

The patient chair is blocked if the manual Cuspidor is turned out to the patient side

Communication overview

This section describes the overall functionality of the electronic print on the Heka G⁺. The purpose is to provide an adequate overview to rapidly identify and localize any operating issues.

Thanks to the large number of indicators, it is possible to quickly get a visual overview of the system status.

Block diagram

The complete unit structure can be outlined as in the following block diagram.

The block diagram shows only the overall connections of the base modules of the unit.

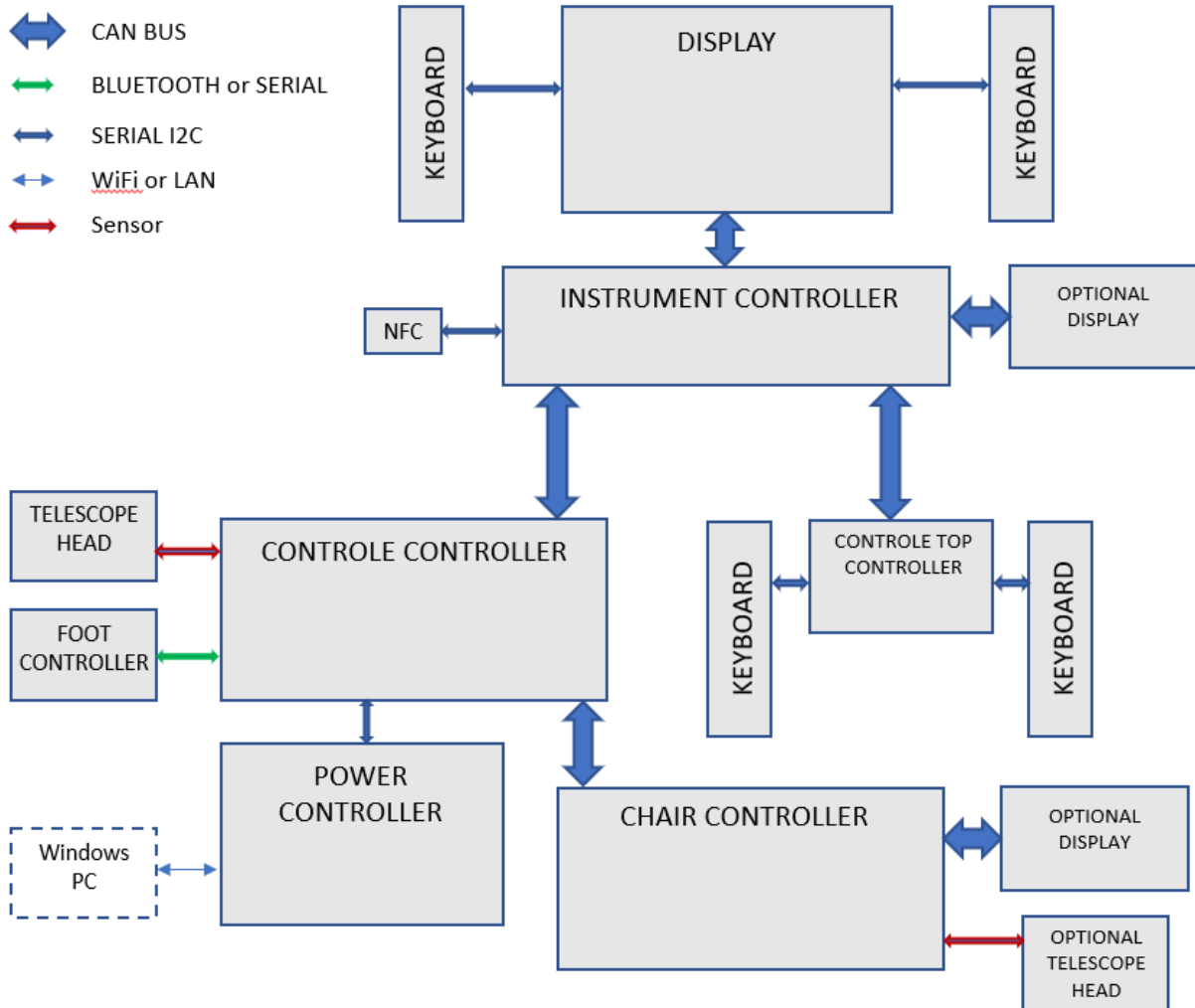

General technical information

- It is the **Console Controller** that runs the application software and control the whole unit. Furthermore this board controls Main Valves, Suction valves, Suction stop, Suction motor switch, Suction clean system, Bowl rinse valve, Cup fill valve, Bottle water valves, Vacuum measurement, Bell switch, speaker, OP lamp control, Spittoon valve interface and interfaces to Foot Controller, -Bluetooth and wired, and the Telescope head sensors.
- The **Console Top Board** handles the console top light and console top keyboards
- The **Power Board** generates the 24Vdc and 34Vcd that supply the rest of the system. Furthermore, it includes a Linux module that handles the Web interface, manage software update and Ethernet interface.
- The **Instrument Controller** handles all instruments and options placed in the instrument table, including speaker, NFC reader and sterile water motor.
- The **Display Board** handles the graphical touch display and the touch keyboards.
- The **Chair Controller** controls the back and seat motors, safety and emergency stop. Furthermore, it interfaces to telescope head detectors, a suction stop button, a programming button, a speaker and a joystick.

Warnings and error descriptions from the system

Severity	Description	Info
Warning	Administrator password is default	Set a unique administrator password to protect the unit
Warning	Default technician password	Set a unique technician password to protect the unit
Failure	Instrument active at startup	Place all equipment in their holders
Failure	Foot control active	A button is pressed or if spring loaded pedal is used, it may not be in resting position
Failure	Suction foot-switch pressed at startup	Release pressure on the foot switch
Warning	Foot control battery low	Connect the foot control via cable to charge the battery
Failure	No foot control paired with unit	Connect a foot control with cable to pair
Failure	Foot control not connected	Connect the foot control with cable
Failure	Chair joystick active at startup	Release pressure on chair joystick
Failure	Chair emergency break	Release pressure on emergency break and power the unit off and on
Failure	Suction vacuum not OK	Contact service technician
Warning	The unit was turned off before completing suction cleaning	Please clean the suction now
Warning	The unit was turned off without completing instrument flush	Please perform instrument flush now
Warning	Chair base motor working time exceeded	Do not use the base motor for two minutes
Warning	Chair back motor working time exceeded	Do not use the base motor for two minutes

Component & Performance Specification

Main Unit

Components:	Five main PCB's (Base Power, Console Controller, Console Top Controller, Instrument Controller and Display Controller. Torodial Transformers Air/Water Valves & Tubing Amalgam Separator Water Container Instrument Arm & Table Instrument Tray and Table Handles Display Screen and Keypad
Materials:	Aluminum (Instrument Arm, Console, Table, Tray, & Handles) Molded Thermoplast (Instrument Rest) Acrylic Glass (Display) Polybutylene Terephthalate PBT (Amalgam Separator) Polyether-PUR Elastollan 1198A (Internal Air/Water Tubing)
Dimensions:	Length 24,0"/610 mm Width 7.9"/200 mm Height 33.5"/850 mm
Performance Specifications:	Power Supply 115V/230V 50/60Hz Frequency Mains: 50/60Hz Air Pressure 65 – 88psi (110psi – maximum) Water Pressure .15 liters/minute Suction Flow 67.0 – 80.0 liters/minute

Foot Control

Components:	Top Ring Middle Ring Activation Ring Pedal Arm Power Connection to Console
Materials:	ABS Plastic
Dimensions:	Diameter 5.51"/140mm Height 2.76"/ 70mm
Performance Specifications:	Top Button Operating Lamp On/Off Middle Ring Air/Water Spray, Chip Blow, Program selection Activation Ring Start Motor (standard foot control) Pedal Arm Increase/Decrease Instrument Intensity (variable foot control) Increase/Decrease Instrument Intensity (standard foot control) Power Connection to Console Connection to console for power to foot control

Heka Patient Chair

Components:	<p>Chair controller PCB</p> <p>Actuators 3 pcs</p> <p>Safety stop (Backrest, leg rest)</p> <p>Chair base</p> <p>Headrest</p> <p>Backrest</p> <p>Armrest</p>
Materials:	<p>Structured steel, aluminium, and plastic</p> <p>Continental Skai® Evida or Toronto</p>
Dimensions:	<p>Chair length 69.5" – 75,4"/1765mm – 1915mm</p> <p>Chair height 20" – 40.1"/510mm – 1010mm</p> <p>Base length 27.2"/690mm</p> <p>Base width 19.3"/490mm</p>
Performance specifications:	<p>Weight load: 200 Kg/440.9 lbs</p> <p>Range of vertical motion: Approximated Trendelenburg: 410/+500 mm</p> <p>Horizontal seat: 460/+500 mm</p> <p>Backrest to seat: Minimum 105°/Maximum 180°</p> <p>Seat angle: 7.5°/0°</p> <p>Headrest tilt: Minimum 180°/Maximum 270°</p> <p>Programming capabilities: Four pre-programmed positions</p> <p>Safety stops: Backrest: Upon touching obstructions on the bottom</p> <p>Leg rest: Upon touching obstructions on the back and bottom</p>

Possibility of contact with parts occurring

Part	Operator contact duration	Patient contact duration	Comment
Instrument table, glass plate (any part, display or touch control)	10 s =< t < 1 min 56	T < 1 min 56	Surface Is touched by the operator for activating functions, max 56°C
Instrument table, metal (any part, handles or other)	1 s =< t < 10 s 56	T < 1 min 51	Is touched by the operator for moving the table in position, max 51°C
G+ Instrument table, plastic plate display	10 s =< t < 1 min 60	T < 1 min 50	Is touched by the operator for moving the table in position, max 50°C
Operating lamp enclosure, plastic (any part, handles or clear cover)	1 s =< t < 10 s 71	T < 1 min 60	Is touched by the operator for moving the lamp in position, , max 60°C
Telescope arm (suction tube holder)	1 s =< t < 10 s 56	T < 1 min 51	Telescoparm handled during treatment by the operator, max 51°C
Enclosure unit, metal (any part)	1 s =< t < 10 s 56	T < 1 min 51	Can be in patient contact during treatment, max 51°C
Enclosure unit, glass top plate	1 s =< t < 10 s 66	T < 1 min 56	Surface Is touched by the operator for activating functions, max 56°C
Chair Upholstery (applied part)	N/A	10 min =< t 43	Can be in patient contact during treatment, max 43°C
Chair Enclosure, metal	1 s =< t < 10 s 56	T < 1 min 51	Is touched by the operator for moving the table in position, max 51°C
Foot control Enclosure, plastic	10 s =< t < 1 min 60	N/A	Is touched by the operator for control of instruments & lamp. max 60°C
Foot control Enclosure, metal	1 s =< t < 10 s 56	N/A	Is touched by the operator for moving the footcontrol in position, max 56°C
Charger enclosure, plastic	1 s =< t < 10 s 71	N/A	Is touched by the operator by charging of the footcontrol. max 71°C

The temperature can be above the maximum temperature look in the table below:

Area	Surface temperature	Duration of safe contact
Enclosure unit, glass top plate touch (C)	45	T < 1 min.
S+ Instrument table, glass plate display	49	T < 1 min.
G+ Instrument table, plastic plate display	50	T < 1 min.
Operating lamp enclosure, plastic	59	T < 1 min.

Warranty Terms & Conditions

Warranty applicable to Heka S+ / Heka G+ and variants & Heka Patient Chair.

- The installation must always be approved by an authorised service technician (Heka Certified technician, HCt). A HCt means that the technician has participated in technical training on the product in question, that the training is offered by Heka Dental, and the HCt has received a course certificate for complete training.
- The equipment is covered by a 24-month warranty (from the installation date) on the condition that the equipment has been checked by a Heka Certified technician and an annual service check is performed within 12 months after the installation date.
- Annual service checks must be performed by a Heka Certified technician using an original Heka Service Kit.
- The installation registration constitutes necessary documentation that the dentist has been adequately instructed in the basics of the new equipment, which decreases the risk of incorrect usage and unnecessary reporting of errors. The Heka Certified technician shall sign the installation registration.
- The Heka Distributor must maintain the installation registration for verification of complete installation.
- Upon request, the Heka Distributor shall provide evidence of the signed Installation card to Heka Dental for installation verification.
- **The warranty is cancelled if the annual service check has not been completed, or the installation registration or service registration cannot be submitted in due time to Heka Dental upon request.**

Option to extend the warranty:

- Heka Dental offers the option to purchase a warranty extension covering, according to the agreement, the years 3-5 or 3-7 from installation.
- A service agreement covering annual service checks by a Heka Certified technician using original Heka Dental Service Kits is a prerequisite for the extension.
- The extension must be purchased no later than 24 months after the original installation date.
- The extension is valid from registration of the 24-month service at Heka Dental
- All warranty repairs must be performed by a Heka Certified technician
- The following years' registrations must be received by Heka Dental within 15 days from the day the annual service check is performed.

The following general terms apply to the warranty:

- Heka Dental does not cover the Heka Distributor's labour, travel and lodging expenses on warranty repairs.
- Heka Dental cannot be held liable for defects and consequential damage in the event of failure to use the equipment correctly.
- Heka Dental cannot be held liable for defects and consequential damage caused by wear and tear, incorrect cleaning or maintenance, lack of compliance with operating, maintenance and connection manuals, calcium build-up, corrosion, contaminated air, water supply or chemical and/or electrical factors that are regarded as abnormal or do not accord with the manufacturer's specifications and instructions.
- This warranty does not cover electrical bulbs/LEDs, glass, rubber parts, instrument hoses, O-rings, chair upholstery or other wearing parts or discoloration of plastic parts.
- OEM products (instruments, instrument accessories, handpieces, suction systems (separator, separator drain pump, central suction, tubing system, etc.), amalgam separators, separators, water purification system etc.) which are not proprietary Heka Dental products are covered by the manufacturer's 12- or 24-month warranty – please see individual manufacturer websites for information on warranty terms.
- Defects and consequential damage that can be attributed to the Heka Distributor or modifications made to the product by third parties are not covered by this warranty.

Exchangeable parts

In order to provide our customers with a fast and efficient service after the end of the warranty period, Heka Dental offers a number of exchangeable parts at a fixed repair price outside the warranty. These only apply to equipment being serviced (standard service and annual service) by a Heka Distributor. Original Heka Dental parts must be used for both standard services and for the annual service check.

IFUs and Label Language Requirements

Heka Dental aims to provide the market with information accompanying our medical devices in the official languages defined by the EU MDR Article 10(11).

If you, as a customer, have a request for accompanying information in a local language from Heka Dental, please get in touch with your authorized Heka Dental distributor

Installation/Service card

The installation/service card can be found in the plastic folder on the inside of the cover on the console.



Online product registration

Installation card

Activate the product warranty
Scan the QR code for online registration of the installation card.



Service card

Maintain the product warranty
Scan the QR code for online registration of the service card.



It is possible to enter installation and inspection cards on our website. (Requires login)
heka-dental.com/support/produktregistrering-eftersyn

Online user registration for dentists

Register as a user of a Heka unit

Access special product information
Scan the QR code for online registration



You can e.g. access special software, user guides, quick guides, user guides videos, tips & tricks, product news, etc. We are constantly expanding the possibilities for registered users of Heka units.

HEKA
DENTAL®

Heka Dental A/S
Baldershej 38
DK-2635 Ishej
Denmark
T: +45 43 32 09 90
M: info@heka-dental.dk
www.heka-dental.com



Homepage



Facebook



LinkedIn



Instagram

Attention

Warranty is only valid if the Dental Delivery System is serviced annually with the original Heka Service Kits and the installation/service cards, along with the original Heka Service Kit serial numbers, are submitted to Heka Dental A/S upon request.

EMC Informations

Guidance and manufacturer's declaration – electromagnetic emissions		
The Dental Delivery System is intended for use in the electromagnetic environment specified below. The customer or the user of the Dental Delivery System should assure that it is used in such an environment.		
Emmissions test	Compliance	Electromagnetic environment - guidance
RF emissions CISPR 11	Group 1	Dental Delivery System uses HF energy only for its internal function. Therefore, its HF emissions are very low and are not likely to cause any interference in nearby electronic equipment.
RF emissions CISPR 11	Class B	Dental Delivery System is suitable for use in all establishments, including domestic establishments and those directly connected to the public low-voltage power supply network that supplies buildings used for domestic purpose.
Harmonic emissions IEC 61000-3-2	Class A	
Voltage fluctuations/ Flicker emissions IEC 61000-3-3	Complies	

Guidance and manufacturer's declaration – electromagnetic emissions			
The Dental Delivery System is intended for use in the electromagnetic environment specified below. The customer or the user of the Dental Delivery System should assure that it is used in such an environment.			
Immunity test	IEC 60601 Test level	Compliance level	Electromagnetic environment-guidance
Electrostatic Discharge (ESD) IEC 61000-4-2	±6 kV contact ±8 kV air	± 2/4/6 kV contact discharge ±2/4/8 kV air	Floor should be concrete, ceramic tile or other nonflammable material. With synthetic material, the relative humidity should be at least 30%.
Electrical fast transient/burst IEC 61000-4-4	±2 kV for power supply lines ±1 kV for input/output lines	±2 kV for power supply lines ±1 kV for input/output lines	Mains power quality should be that of a typical commercial or hospital environment.
Surge According to IEC 61000-4-5 Surge Line to Ground a)	± 1 kV push-pull voltage ± 2 kV common mode voltage	± 1 kV push-pull voltage ± 2 kV common mode voltage	Mains power quality should be that of a typical commercial or hospital environment.
Voltage dips, short interruptions and voltage variations on power supply input lines. IEC 61000-4-11	<5 % U_T (>95 % dip in U_T) for 0,5 cycle 40 % U_T (60 % dip in U_T) for 5 cycles 70 % U_T (30 % dip in U_T) for 25 cycles <5 % U_T (>95 % dip in U_T) for 5 s (250 periods)	<5 % U_T (>95 % dip in U_T) for 0,5 cycle 40 % U_T (60 % dip in U_T) for 5 cycles 70 % U_T (30 % dip in U_T) for 25 cycles <5 % U_T (>95 % dip in U_T) for 5 s (250 periods)	Mains power quality should be that of a typical commercial or hospital environment. If the user of Dental Delivery System requires continued operation during power mains interruptions, it is recommended that the Dental Delivery System be powered from an uninterruptible power supply.
Power frequency (50/60 Hz) magnetic field IEC 61000-4-8	3 A/m	3 A/m	Power frequency magnetic fields should be at levels characteristic of a typical location in a typical commercial or hospital environment. The power frequency magnetic field should be measured in the intended installation location to assure that it is sufficiently low.
NOTE: U_T is the a.c. mains voltage prior to application of the test level			

Guidance and manufacturer's declaration – electromagnetic emissions			
The Dental Delivery System is intended for use in the electromagnetic environment specified below. The customer or the user of the Dental Delivery System should assure that it is used in such an environment.			
Immunity test	IEC 60601 Test level	Compliance level	Electromagnetic environment- guidance
Wire-based HF interference according to EN 61000-4-6 Wireless HF interference according to EN 61000-4-3	3 V _{eff} 150 kHz to 80 MHz outside the ISM bands ^{a)} 3 V/m 80 MHz to 2.5 GHz	3 V _{eff} 3 V/m	Handheld and mobile wireless devices should not be used at a shorter distance from the Dental Delivery System including cables than the recommended safe clearance calculated using the appropriate equation for the emission frequency. Recommended safe distance: $d = 1.17 P$ $d = 1.17 P$ for 80 MHz to 800 MHz $d = 2.33 P$ for 800 MHz to 2.5 GHz where P is the maximal nominal power of the transmitter in watts (W) as specified by the transmitter manufacturer and d is the recommended safe clearance in metres(m). b) The field strength of stationary wireless radio transmitters as measured locally ^{c)} should be lower than the conformance level at all frequencies. d) Interference is possible in the vicinity of devices bearing the following icon. 
<p>Note 1: At 80 MHz and 800 MHz, the higher frequency range applies.</p> <p>Note 2: These guidelines may not apply in all situations. Electromagnetic propagation is affected by absorption and reflection from structures, objects and people.</p>			
<p>a) The ISM frequency bands (for industrial, scientific, and medical applications) between 150 kHz and 80 MHz are 6.765 MHz to 6.795 MHz; 13.553 MHz to 13.567 MHz; 26.957 MHz to 27.283 MHz, and 40.66 MHz to 40.70 MHz.</p> <p>b) The compliance levels in the ISM frequency bands between 150 kHz and 80 MHz and in the frequency range from 80 MHz to 2.5 GHz are intended to reduce the probability of mobile/handheld communications facilities causing interference when they are inadvertently introduced into the patient area. For this reason, the additional factor of 10/3 is applied in the calculation of the recommended safe clearances in these ranges of frequencies.</p> <p>c) The field strength of stationary transmitters, such as, e.g. base stations of mobile phones and mobile terrestrial radio devices, amateur radio stations, AM and FM radio and television transmitters, cannot be determined exactly based on theoretical considerations. A site study should be considered to determine the electromagnetic environment in terms of stationary transmitters. If the measured field strength at the site, at which the Dental Delivery System is used, exceeds the compliance levels shown above, the Dental Delivery System should be monitored to demonstrate proper function. If any uncommon performance characteristics are observed, additional measures may be required, such as, e.g., changing the orientation or using a different location for the Dental Delivery System.</p> <p>d) In the frequency range of 150 kHz to 80 MHz, the field strength should be less than 3V_{eff} V/m.</p>			

Recommended separation distances between Portable and mobile HF communications equipment and Dental Delivery System			
The Dental Delivery System is intended for use in an electromagnetic environment in which radiated HF disturbances are controlled. The customer or the user of Dental Delivery System can help prevent electromagnetic interference by maintaining a minimum distance between portable and mobile HF communications equipment (transmitters) and the Dental Delivery System as recommended below, according to the maximum output power of the communications equipment. Safe distance depending on the transmission frequency:			
Rated power P of the transmitter in W	Safe distance depending on the transmission frequency in m		
	150 kHz to 80 MHz $d=1.17 P$	80 MHz to 800 MHz $d=1.20 P$	800 MHz to 2.5 GHz $d=2.3 P$
0.01	0.12	0.12	0.23
0.1	0.37	0.38	0.73
1	1.17	1.20	2.3
10	3.69	3.79	7.27
100	11.7	12	23

Data on electromagnetic compatibility according to EN 60601-1-2 10.4 Immunity to electromagnetic interference.			
Rated power P of the transmitter in W	Safe distance depending on the transmission frequency in m		
	150 kHz to 80 MHz $d=1.17 P$	80 MHz to 800 MHz $d=1.20 P$	800 MHz to 2.5 GHz $d=2.3 P$
U1 = Compliance level according to 4-6: 3 Veff E1 = Compliance level according to 4-3: 3 V/m			
Factor	$[3.5/U1]$	$[12/E1]$	$[23/E1]$

For transmitters whose maximum rated power is not in the above table, the recommended safe distance d in meters (m) can be calculated using the equation for the respective gap, where P is the maximum rated power of the transmitter in Watts (W) according to the manufacturer's information.

NOTE 1: At 80 MHz and 800 MHz, the higher frequency range applies.

NOTE 2: These guidelines may not be applicable in every case. The spread of electromagnetic waves is absorbed and reflected by buildings, objects and people.

Disposal of the unit

To reduce the environmental impact of the product throughout its lifetime, the device is designed to be as safe as possible to manufacture, use and dispose of. Components suitable for recycling should always be sent to a recycling centre once all hazardous materials have been removed. Obsolete units are disposed of at the owner's own responsibility and risk. All components and parts containing hazardous materials must be disposed of in compliance with current legislation and the guidelines issued by the environmental authorities. Risks must be considered, and the necessary precautionary measures must be taken when handling waste products.

Part	Primary materials for disposal	Recyclable materials	Environment controlled burning	Landfill waste disposal site	Hazardous waste (separate collection)	
Frame and screening	- Metal	Aluminium	X			
		Stainless steel AISI303/304/316	X			
		Steel	X			
		Galvanized steel	X			
	- Plastic	ABS / ASA	X			
		PVC	X			
		PE (Powder coating)		X		
		PU (Powder coating)		X		
		TPE		X		
		PUR	X			
		PTFE				X
		Other plastic		X		
	Silicone				X	
- Rubber				X		
- Glass		X				
- Porcelain				X		
Motor		(X)				
Component board		(X)				
Cables, transformers	Copper	X				
	Steel	X				
Amalgam separator*)						
Filters					X	
Collection devices					X	
Packaging	Wood	X				
	Cardboard	X				
	Paper	X				
Other parts				X		

Designed and manufactured in our own factory in Denmark, the Heka Units reflects our commitment to innovation, craftsmanship, and quality.

Take a behind-the-scenes look at our modern facilities and discover how we are shaping the future of dental units with solutions tailored to your needs.



HEKA
Factory Tour

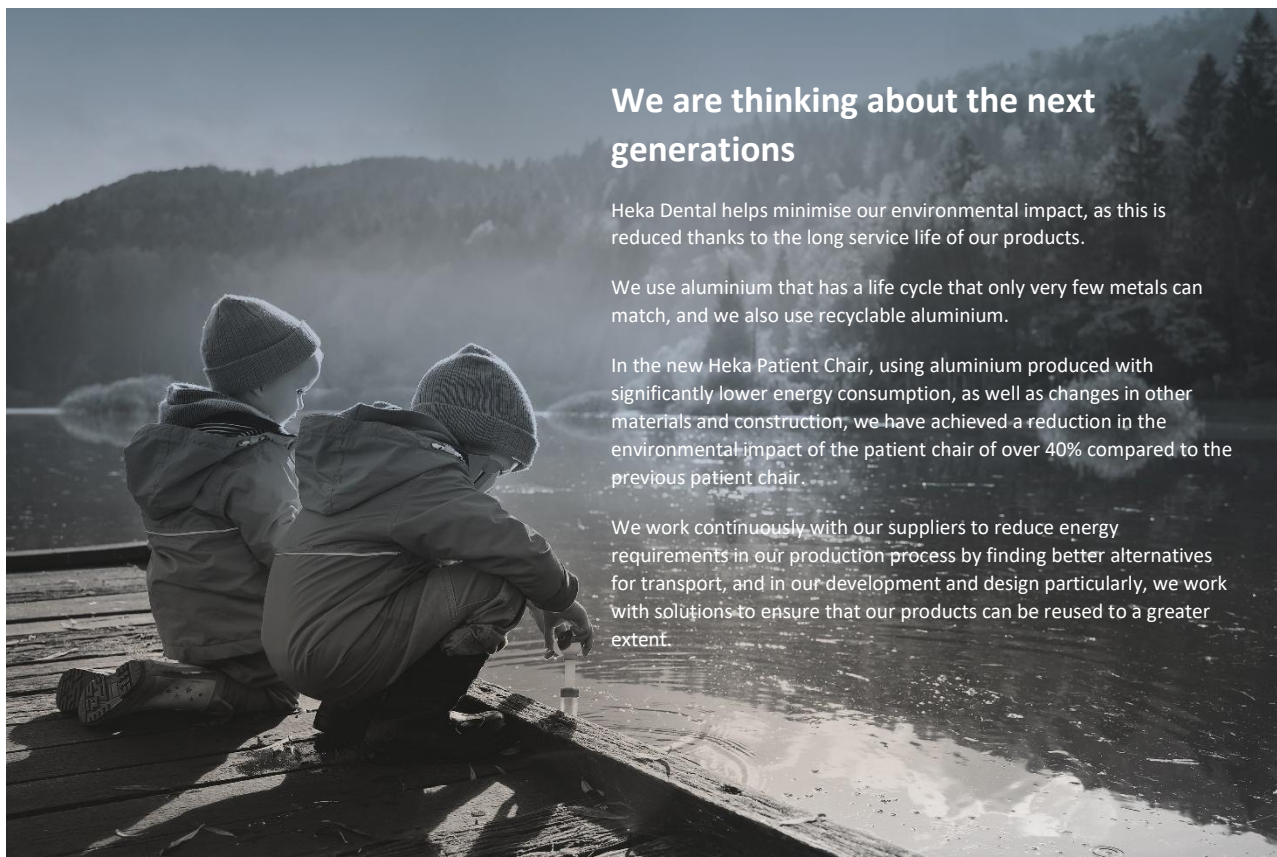

We are thinking about the next generations

Heka Dental helps minimise our environmental impact, as this is reduced thanks to the long service life of our products.

We use aluminium that has a life cycle that only very few metals can match, and we also use recyclable aluminium.

In the new Heka Patient Chair, using aluminium produced with significantly lower energy consumption, as well as changes in other materials and construction, we have achieved a reduction in the environmental impact of the patient chair of over 40% compared to the previous patient chair.

We work continuously with our suppliers to reduce energy requirements in our production process by finding better alternatives for transport, and in our development and design particularly, we work with solutions to ensure that our products can be reused to a greater extent.

Heka Dental A/S is ISO 13485 certified.



Homepage



Facebook



LinkedIn



Instagram