

VSA 300 S

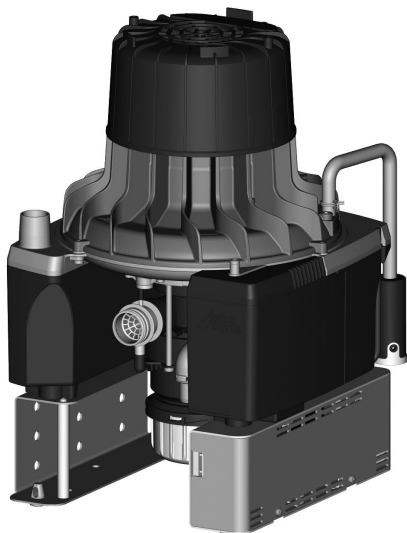

EN Installation and operating instructions



9000-6006-31/02 2505V007

The current version of the installation and operating instructions is available in the Download Center:



<http://qr.duerrdental.com/9000-606-31>

© 2003-2025 DÜRR DENTAL SE

Contents



Important information

1 About this document	3
1.1 Warnings and symbols	3
1.2 Copyright information	4
2 Safety	4
2.1 Intended purpose	4
2.2 Intended use	4
2.3 Improper use	4
2.4 Systems, connection with other devices	5
2.5 General safety information	5
2.6 Specialist personnel	5
2.7 Notification requirement of serious incidents	5
2.8 Electrical safety	5
2.9 Only use original parts	6
2.10 Transport	6
2.11 Disposal	6
2.12 Protection from threats from the Internet	6



Product description

3 Overview	7
3.1 Scope of delivery	7
3.2 Optional items	7
3.3 Consumables	7
3.4 Wear parts and replacement parts	7
4 Technical data	8
4.1 Type plate	12
4.2 Evaluation of conformity	12
4.3 Approvals	12
5 Function	13



Assembly

6 Requirements	15
---------------------------------	----

6.1 Installation/setup room	15
6.2 Setup options	15
6.3 Use of nitrous oxide	15
6.4 Pipe materials	15
6.5 Hose materials	15
6.6 Installation and routeing of hoses and pipes	15
6.7 Information about electrical connections	16
6.8 Information about connecting cables	16
7 System components	17
7.1 OroCup	17
7.2 Rinsing unit	17
7.3 Spittoon valve	17
7.4 Flow accelerator	17
7.5 Exhaust air filter	17
7.6 Noise reduction	17

8 Installation	18
8.1 Installation and routeing of hoses and pipes	18
8.2 Rinsing unit water connections	20
8.3 Electrical connections	21
8.4 Connections and displays of the control	23
8.5 Display panel connection	24
8.6 Network connection	24

9 Commissioning	25
9.1 Monitoring the unit via the network	25

10 Service program	27
-------------------------------------	----

11 Description of the service program	28
11.1 Service program ON/OFF	28
11.2 Display test	28
11.3 Sediment level measurement	28
11.4 Motor start - motor braking	28
11.5 Input and output signals	28



Usage

12 Display/handling	29
12.1 Ready for operation	29

- 12.2 Amalgam collector vessel is 95% full 29
- 12.3 Amalgam collector vessel is 100% full 29
- 12.4 Fill level measurement fault 29
- 12.5 Amalgam collector vessel not in position 29
- 12.6 Motor fault 29
- 12.7 Brake monitoring 30
- 13 Disinfection and cleaning 31**
 - 13.1 Suctioning water 32
 - 13.2 Disinfection 32
 - 13.3 Cleaning 33
- 14 Replace the amalgam collector vessel 35**
 - 14.1 Disposal of amalgam collecting container 35
- 15 Maintenance 36**
 - 15.1 Intensive cleaning 37
 - 15.2 Tests 38



Troubleshooting

- 16 Tips for operators and service technicians 39**
- 17 Transporting the unit 41**



Appendix

- 18 Handover record 42**
- 19 Country representatives 43**

Important information

1 About this document

These installation and operating instructions represent part of the unit.



The manufacturer and the distributor will not offer any guarantee or accept any liability for the safe operation and the safe functioning of the unit if the instructions and information in these installation and operating instructions are not complied with.

The German version of the installation and operating instructions is the original manual. All other languages are translations of the original manual. These installation and operating instructions apply to:

VSA 300 S

REF: 7125-01; 7125-01/002; 7125-01/021;
7125-03; 7125-03/002; 7125-04/002

1.1 Warnings and symbols

Warnings

The warnings in this document are intended to draw your attention to possible injury to persons or damage to machinery.

The following warning symbols are used:



General warning symbol



Warning – dangerous high voltage



Warning – hot surfaces



Warning - automatic start-up of the unit



Biohazard warning

The warnings are structured as follows:



SIGNAL WORD

Description of the type and source of danger

Here you will find the possible consequences of ignoring the warning

- Follow these measures to avoid the danger.

The signal word differentiates between four levels of danger:

- **DANGER**
Immediate danger of severe injury or death
- **WARNING**
Possible danger of severe injury or death
- **CAUTION**
Risk of minor injuries
- **NOTICE**
Risk of extensive material/property damage

Other symbols

These symbols are used in the document and on or in the unit:



Note, e.g. specific instructions regarding efficient and cost-effective use of the unit.



Refer to the accompanying electronic documents.



Disconnect all power from the unit.



Wear protective gloves.



Wear protective goggles.



Use a face mask.



Sunrise / mornings



Lower and upper temperature limits



Lower and upper humidity limits



Do not reuse



Unit in operation



Unit operation interrupted



Audible signal/melody sounds



Protective ground connection



Mark of conformity from the Deutsches Institut für Bautechnik



CE labelling with the number of the notified body



Conformity mark for the United Kingdom of Great Britain and Northern Ireland, with the number of the designated authority



Order number



Serial number



Medical device



Health Industry Bar Code (HIBC)



Manufacturer

1.2 Copyright information

All circuits, processes, names, software programs and units mentioned in this document are protected by copyright.

The Installation and Operating Instructions must not be copied or reprinted, neither in full nor in part, without written authorisation from the copyright owner.

2 Safety

The unit has been developed and designed in such a way that dangers are effectively ruled out if used in accordance with the Intended Use. Despite this, the following residual risks can remain:

- Personal injury due to incorrect use/misuse
- Personal injury due to mechanical effects
- Personal injury due to electrical shock
- Personal injury due to radiation
- Personal injury due to fire
- Personal injury due to thermal effects on skin
- Personal injury due to lack of hygiene, e.g. infection

2.1 Intended purpose

The suction machine provides a suction output to the dental treatment unit and is designed for continuous separation of liquids and air and for separation of amalgam from the entire waste water from dental treatment units.

2.2 Intended use

The suction machine is designed for installation downstream of the hose manifold and spittoon bowl of dental treatment units.

Service, maintenance, recurring tests and cleaning must be performed in accordance with the manufacturer's specifications.

The permissible flow rate must be observed.

The disposable amalgam containers must only be used once.

A rinsing unit is required for surgical procedures and for procedures using prophylaxis powders.

2.3 Improper use

Any use of this appliance / these appliances above and beyond that described in the Installation and Operating Instructions is deemed to be incorrect usage. The manufacturer cannot be held liable for any damage resulting from incorrect usage. The operator will be held liable and bears all risks.

This includes:

- Use for suction and separation of dust, sludge or plaster
- Use in conjunction with flammable or explosive mixtures
- Cleaning and disinfection with agents containing sodium hypochlorite or potassium hypochlorite
- Installation in a manner that does not comply with the installation instructions, in particular installation in rooms containing a potentially explosive atmosphere
- Installation without a downward gradient to allow the water to drain off

2.4 Systems, connection with other devices

Additional devices connected with medical electrical devices must be proven to conform with their corresponding IEC or ISO standards. All configurations must continue to comply with the standard requirements for medical systems (see IEC 60601-1).

Whoever connects additional devices to medical electrical devices automatically becomes the system configurator and is responsible for ensuring that the system corresponds with the standard requirements for systems. Local laws take priority over the requirements outlined above.

2.5 General safety information

- Always comply with the specifications of all guidelines, laws, and other rules and regulations applicable at the site of operation for the operation of this unit.
- Check the function and condition of the unit prior to every use.
- Do not convert or modify the unit.
- Comply with the specifications of the Installation and Operating Instructions.
- The Installation and Operating Instructions must be accessible to all operators of the unit at all times.

2.6 Specialist personnel

Operation

Unit operating personnel must ensure safe and correct handling based on their training and knowledge.

- Instruct or have every operator instructed in handling the unit.

Installation and repairs

- The manufacturer recommends that installation, readjustments, alterations, upgrades and repairs be carried out either by the manufacturer itself or by a qualified specialist authorised by the manufacturer.

2.7 Notification requirement of serious incidents

The operator/patient is required to report any serious incident that occurs in connection with the device to the manufacturer and to the competent authority of the Member State in which the operator and/or patient is established/resident.



Notify the manufacturer of any serious incidents under the following email address: incidents@duerrdental.com.

2.8 Electrical safety

- Comply with all the relevant electrical safety regulations when working on the unit.
- Never touch the patient and unshielded plug connections on the unit at the same time.
- Replace any damaged cables or plugs immediately.

Observe the EMC rules concerning medical devices

- The unit is intended for use in professional healthcare facilities (in accordance with IEC 60601-1-2). If the appliance is operated in another environment, potential effects on electromagnetic compatibility must be taken into account.
- Do not operate the unit in the vicinity of RF surgical instruments or MRT equipment.
- Maintain a minimum distance of at least 30 cm between the unit and other electronic devices.
- Note that cable lengths and cable extensions have effects on electromagnetic compatibility.

No maintenance measures are required to maintain the EMC basic safety.



NOTICE

Negative effects on the EMC due to non-authorised accessories

- › Use only those accessories named or approved by the manufacturer.
- › Using any other accessories may result in increased electromagnetic interference emissions or the unit having reduced electromagnetic immunity, leading to an erroneous operation mode.



NOTICE

Erroneous operation mode due to use immediately adjacent to other devices or with other stacked devices

- › Do not stack the unit together with other devices.
- › If this is unavoidable, the unit and other devices should be monitored in order to ensure that they are working correctly.



NOTICE

Reduced performance characteristics due to insufficient distance between unit and portable HF communication devices

- › Keep a distance of at least 30 cm between the unit (including parts and cables of the unit) and portable HF communication devices (wireless units) (including their accessories such as antenna cables and external antennas).

2.9 Only use original parts

- Only use accessories and optional articles named or authorised by the manufacturer.
- Only use only original wear parts and replacement parts.

2.10 Transport

The original packaging provides optimum protection for the unit during transportation. If required, the original packaging for the unit can be ordered.



The manufacturer and the distributor do not accept liability, even during the warranty period, for damage during transportation due to improper packaging.

- Only transport the unit in its original packaging.
- Keep the packing materials out of the reach of children.

2.11 Disposal



The unit may be contaminated. Instruct the company disposing of the waste to take the relevant safety precautions.

- Decontaminate potentially contaminated parts before disposing of them.
- Uncontaminated parts (e.g. electronics, plastic and metal parts etc.) should be disposed of in accordance with the local waste disposal regulations.
- If you have any questions about the correct disposal of parts, please contact your dental trade supplier.



An overview of the waste keys for Dürr Dental products can be found in the download area:



<http://qr.duerrdental.com/P007100155>

2.12 Protection from threats from the Internet

The unit is to be connected to a computer that can be connected to the Internet. Therefore, the system needs to be protected from threats from the Internet.

- Use antivirus software and update it regularly. Look for evidence of possible virus infection and, if applicable, check with the antivirus software and remove the virus.
- Perform regular data backups.
- Restrict access to units to trustworthy users, e.g. via a user name and password.
- Make sure that only trustworthy content is downloaded. Only install software and firmware updates that have been authenticated by the manufacturer.



Product description

3 Overview

3.1 Scope of delivery

The following items are included in the scope of delivery (possible variant-specific deviations due to country-specific requirements and/or import regulations):

VSA 300 S, 230 V AC, 50 Hz 7125-01

VSA 300 S, 230 V AC, 50 Hz with

installed rinsing unit 7125-03

- Connector set
- Protective strainer with connecting parts
- Remote display
- Disposable amalgam container
- Short description
- Operating Handbook

VSA 300 S, 230 V AC, 50 Hz 7125-01/002

VSA 300 S, 230 V AC, 50 Hz with

installed rinsing unit 7125-03/002

- Connection parts
- Connector set
- Remote display
- Hose LW 20
- Suction hose LW 30, grey
- Hose LW 30, aluminium
- Disposable amalgam container
- Short description
- Operating Handbook
- OroCup

VSA 300 S, 230 V AC, 50 Hz 7125-01/021

VSA 300 S, 230 V AC, 60 Hz 7125-04/002

3.2 Optional items

The following optional items can be used with the device:

Rinsing unit conversion set for

VS 300 S and VSA 300 S 7100-120-53

Rinsing unit II 7100-250-50

Bacteria filter with accessories 7120-143-00

Bacteria filter with housing 7120100000

Noise reduction hood 7122200000

Ventilation kit for cabinet installation 7122-981-51

Secretion filter 7123-120-00

Wall bracket 7130-190-00

Console for floor-mounted installation 7130-191-00

3.3 Consumables

The following materials are consumed during operation of the device and must be ordered separately:

Disposable amalgam container 7110-033-00

Orotol plus (2.5 litre bottle) CDS110P6150

MD 550 spittoon bowl cleaner

(750 ml bottle) CCS550C4500

MD 555 cleaner (2.5 litre bottle) CCS555C6150

3.4 Wear parts and replacement parts

The following working parts need to be changed at regular intervals (refer to the "Maintenance" section):



Information about replacement parts can be found on the website portal for specialist dealers under:
www.duerrdental.net

4 Technical data

Electrical data		7125-01	7125-03	7125-04
Rated voltage	V	230, 1~	230, 1~	230, 1~
Mains frequency	Hz	50	50	60
Nominal current	A	2.9	2.9	3.4
Starting current, approx.	A	16	16	16
Motor protection		Motor winding overheat protector 160 °C (±5 °C)		
Rated power	W	580	580	800
Type of protection			IP 20	
Protection class			I	
Protective low voltage	V		24 ~	
Output	VA		4	
Connections				
Suction connection, DürrConnect special	mm		Ø 30	
Exhaust air connection (external)	mm		Ø 30	
Drain connection, DürrConnect	mm		Ø 20	
Media				
Max. flow rate with unimpeded flow	l/min	700	700	800
Max. suction system pressure	mbar/hPa		-200	
Flow rate				
min.	l/min		0.1	
max.	l/min		4	
Max. suction height	cm		50	
Usable volume of collecting container, approx.	ccm		150	
Replacement interval	Months		6 - 9	
General data				
Number of users, max.			1	
Duty cycle	%		100 (S1)	
Heat generation rate	kJ/h		2880	
Dimensions (H x W x D) *	cm	47 x 31 x 32	47 x 31 x 33	47 x 31 x 32
Weight, approx.				
without housing	kg	15.4	15.7	15.4
with housing	kg	23.4	23.7	23.4
Noise level ** approx.				
without housing	dB(A)	61	61	63
with housing	dB(A)	50	50	54

General data

- * Values without accessories and add-on parts
- ** Sound pressure level in accordance with ISO 3746

Network connection

LAN technology	Ethernet
Standard	IEEE 802.3u
Data rate	Mbit/s 100
Connector	RJ45
Type of connection	Auto MDI-X
Cable type	≥ CAT5

Ambient conditions during storage and transport

Temperature	°C	-10 - +60
Relative humidity	%	< 95

Ambient conditions during operation

Temperature	°C	+10 - +40
Relative humidity	%	< 70

Classification

Medical Device Class (MDR)	IIa
----------------------------	-----

Electromagnetic compatibility (EMC)**Interference emission measurements**

Interference voltage at the power supply connection CISPR 11:2015/AMD1:2016	Group 1 Class B
Electromagnetic interference radiation CISPR 11:2015/AMD1:2016	Group 1 Class B
Intermittent interference voltage at the power supply connection CISPR 14-1:2016	Group 1 Class B
Emission of harmonics IEC 61000-3-2:2018	Compliant
Voltage changes, voltage fluctuations and flicker emissions IEC 61000-3-3:2013/AMD1:2017	Compliant

Electromagnetic compatibility (EMC)**Interference immunity measurements cover**

Immunity to interference, discharge of static electricity IEC 61000-4-2:2008 ± 8 kV contact ± 2 kV, ± 4 kV, ± 8 kV, ± 15 kV air	Compliant
--	-----------

**Electromagnetic compatibility (EMC)
Interference immunity measurements cover**

Immunity to interference, high-frequency electromagnetic fields

IEC 61000-4-3:2006+A1:2007+A2:2010
3 V/m

Compliant

80 MHz - 2.7 GHz

80 % AM at 1 kHz

Immunity to interference from power frequency magnetic fields

IEC 61000-4-8:2009
30 A/m at 50 Hz

Compliant

Immunity to interference, near fields of wireless HF communication devices

IEC 61000-4-3:2006+A1:2007+A2:2010

Compliant

Immunity to interference table, near fields of wireless HF communication devices

Radio service	Frequency band MHz	Test level V/m
TETRA 400	380 - 390	27
GMRS 460 FRS 460	430 - 470	28
LTE band 13, 17	704 - 787	9
GSM 800/900 TETRA 800 iDEN 820 CDMA 850 LTE band 5	800 - 960	28
GSM 1800 CDMA 1900 GSM 1900 DECT LTE band 1, 3, 4, 25 UMTS	1700 - 1990	28
Bluetooth WLAN 802.11 b/g/n RFID 2450 LTE band 7	2400 - 2570	28
WLAN 802.11 a/n	5100 - 5800	9

**Electromagnetic compatibility (EMC)
Interference immunity measurements supply input**

Immunity to interference, rapid transient bursts – AC voltage grid

IEC 61000-4-4:2012
± 2 kV

Compliant

100 kHz repetition frequency

Electromagnetic compatibility (EMC)**Interference immunity measurements supply input**

Immunity to interference, surges
IEC 61000-4-5:2014/AMD1:2017
 $\pm 0.5 \text{ kV}$, $\pm 1 \text{ kV}$, L - N
 $\pm 0.5 \text{ kV}$, $\pm 1 \text{ kV}$, $\pm 2 \text{ kV}$, L/N - PE

Compliant

Immunity to interference, line-conducted disturbances
induced by high-frequency fields – AC voltage grid
IEC 61000-4-6:2013
3 V
0.15 - 80 MHz
6 V
ISM frequency bands
6.765 - 6.795 MHz
13.553 - 13.567 MHz
26.957 - 27.283 MHz
40.66 - 40.70 MHz
80 % AM at 1 kHz

Compliant

Immunity to interference due to voltage dips, short inter-
ruptions and voltage variations
IEC 61000-4-11:2004/AMD1:2017

Compliant

Electromagnetic compatibility (EMC)**Interference immunity measurements SIP/SOP**

Immunity to interference, rapid transient bursts – I/O,
SIP/SOP ports
IEC 61000-4-4:2012
 $\pm 1 \text{ kV}$
100 kHz repetition frequency

Compliant

Immunity to interference, line-conducted disturbances
induced by high-frequency fields – SIP/SOP ports
IEC 61000-4-6:2013
3 V
0.15 - 80 MHz
6 V
ISM frequency bands
6.765 - 6.795 MHz
13.553 - 13.567 MHz
26.957 - 27.283 MHz
40.66 - 40.70 MHz
80 % AM at 1 kHz

Compliant

4.1 Type plate

The type plate can be found on the noise reduction hood.

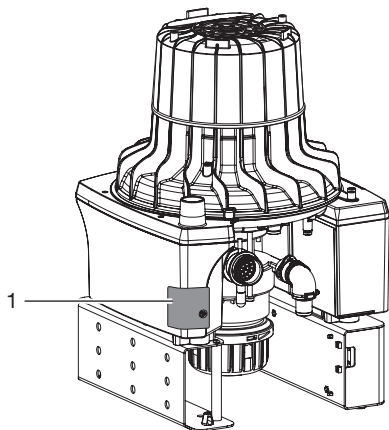

1 Type plate

4.2 Evaluation of conformity

This device has been subjected to conformity acceptance testing in accordance with the current relevant European Union guidelines. This equipment conforms to all relevant requirements.

4.3 Approvals

**Centre of Competence in Civil Engineering,
Berlin**

Test number	Z-64.1-15
-------------	-----------

Separation method compliant with standard

ISO 11143	Type 1
-----------	--------

5 Function

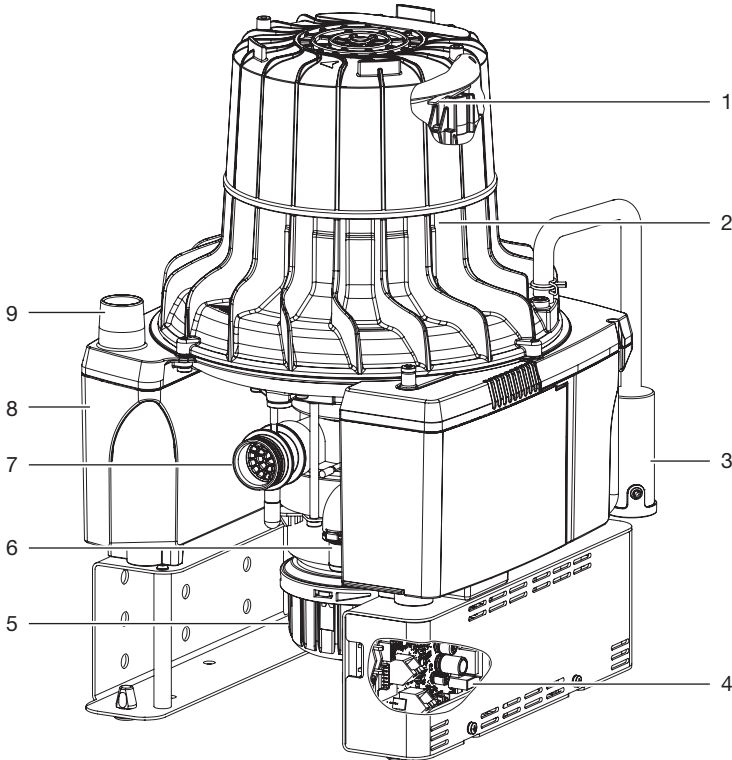

- 1 Rotational speed sensor
- 2 Motor
- 3 Auxiliary air nozzle
- 4 Control electronics
- 5 Amalgam collecting container
- 6 Waste water connection
- 7 Inlet connection with protective coarse filter
- 8 Exhaust air muffler
- 9 Exhaust air connection

The mixture of liquids, solid particles and air drawn in passes through the inlet connection and into the suction unit. The coarse filter holds back the solid particles.

Inside the separation unit, the aspirated fluids and solid particles pass through a two-stage separation system and are separated from the suction air. This separation system consists of a cyclone separator and a separation turbine.

The aspirated mixture flows into the cyclonic separator, where it is set into a spiral motion. In this first stage, the resulting centrifugal forces force the fluid constituents and any remaining solid particles against the outside wall of the separation chamber of the cyclone separator. This initially only effects a "coarse separation" of the fluid.

In the subsequent second stage, the separation turbine effects "fine separation" of the remaining liquid from the air flow that has carried it to this point.

The fluid and solids accreting in the separation chamber are continuously fed to the amalgam centrifuge, where the amalgam particles are removed. The fluid extracted via the centrifuge is fed through the waste water valve and the outlet connection into the central waste-water system.

Under the centrifuge there is an interchangeable collecting container into which the separated amalgam particles fall once the motor is switched off.

A sensor checks the fill level in the collecting container, and when it is full, an LED on the display panel indicate that the collecting container needs to be replaced. Depending on the type of work carried out and the amount of amalgam arising, the collector vessel should be changed approx. every 6-9 months. A secure twist cap makes the replacement and closing of the collector vessel easier.

A pump connected to the centrifuge keeps the fluid level constant in the collecting container. This prevents accidental overflow when replacing the collecting container.

The air separated from the liquid is sucked off by the vacuum pressure generated by the turbine wheel. The air is then blown through the noise reduction hood and over the exhaust air connection and out of the machine.

The turbine wheel, separation turbine and amalgam centrifuge are driven by the motor.

An auxiliary air nozzle is connected to the turbine housing. The auxiliary air nozzle limits the vacuum in the system. In certain working situations it also sucks additional cooling air into the machine.



6 Requirements

The unit can be installed on the same level as the surgery room or in a floor below.



Further information can be found in our suction planning information leaflet.
Order number 9000-617-03/..

6.1 Installation/setup room

The room chosen for set up must fulfil the following requirements:

- Closed, dry, well-ventilated room
- Should not be a room made for another purpose (e. g. boiler room or wet cell)
- When installing in a cabinet the inlet and outlet ventilation slots must be present; minimum free cross-section at least 120 cm².
- Forced ventilation (fan) must be provided if there is a risk that the recommended room air temperature could be exceeded. The air flow performance must be at least 2 m³/min.
- Do not cover cooling slots or openings with housing installations; ensure sufficient clearance to the openings to permit sufficient cooling.

6.2 Setup options

The following options for setting up the unit are available:

- Wall installation using a Dürr Dental wall mounting
- In a ventilated cabinet
- In a Dürr Dental noise reducing housing



When installed in a basement or a similar room, the unit must be placed on a base or be fixed to the wall at a minimum height of 30 cm above the floor.

6.3 Use of nitrous oxide

This unit is technically suitable for the aspiration of nitrous oxide (laughing gas). However, when assembling a system for aspiration of nitrous oxide, it is important to ensure that the other components in the system are also suitable for

this purpose. Those responsible for setting up the system must assess this and approve and release the system for the aspiration of nitrous oxide.



Operation with nitrous oxide is only permitted if the exhaust air is transported from the unit to the outside of the building.

6.4 Pipe materials

Only use vacuum-sealed HT-waste pipes manufactured from the following materials:

- Polypropylene (PP),
- Chlorinated polyvinyl chloride (PVC-C),
- Plasticizer-free polyvinyl chloride (PVC-U),
- Polyethylene (PE).

The following materials must not be used:

- Acrylonitrile-butadiene-styrene (ABS),
- Styrene copolymer blends (e.g. SAN + PVC).

6.5 Hose materials

For waste connections and suction lines only use the following hose types:

- Flexible spiral hoses made of PVC with integrated spiral or equivalent hoses
- Hoses that are resistant to dental disinfectants and chemicals



Plastic hoses will display signs of ageing over time. Therefore, they should be inspected regularly and replaced as necessary.

The following types of hoses must not be used:

- Rubber hoses
- Hoses made completely of PVC
- Hoses that are not sufficiently flexible

6.6 Installation and routing of hoses and pipes

1. Execute the on-site pipe installation in accordance with the applicable local regulations and standards.
2. Lay the hose installation of the drains to or from the unit at a sufficient incline.



If incorrectly laid, the hoses can become blocked with sedimentation.

6.7 Information about electrical connections

- Ensure that the electrical connections to the mains power supply are established in accordance with current valid national and local regulations and standards governing the installation of low voltage units in medical facilities.
- Install an all-pole disconnect switch with a contact opening width of at least 3 mm in the electrical connection to the mains power supply.
- Observe the current consumption of the devices that are to be connected.

Electrical fusing

LS switch 16 A, characteristic B, C and D in accordance with 60898.

6.8 Information about connecting cables

The diameter of the connections depends on the current consumption, length of line and the ambient temperature of the unit. Information concerning the current consumption can be found in the Technical Data supplied with the particular unit to be connected.

The following table lists the minimum diameters of the connections in relation to the current consumption:

Current consumption of unit [A]	Cross-section [mm ²]
> 10 and < 16	1.5
> 16 and < 25	2.5

Mains supply cable

Installation type	Line layout (minimum requirements)
Fixed installation	– Plastic sheathed cable (e.g. type NYM-J)
Flexible	– PVC flexible line (e.g. H05 VV-F) or – Rubber connection (e.g. H05 RN-F or H05 RR-F)

Display panel

Installation type	Line layout (minimum requirements)
Fixed installation	– CAT5.e network cable
Flexible	– ISDN standard cable with connectors or – Network patch cable

Control cable

24 V protective low voltage for:

- Hose manifold
- Place selection valve
- Spittoon valve

Installation type	Line layout (minimum requirements)
Fixed installation	– Shielded sheathed cable (e.g. (N)YM (St)-J)
Flexible	– PVC data cable with shielded cable sheathing, as used for telecommunications and IT processing systems (e.g. type LiYCY) or – Lightweight PVC control cable with shielded cable sheathing



Connect the shielding of the cables in accordance with the regulations.

7 System components

The system components listed below are required or recommended for various procedures or for installation.

7.1 OroCup

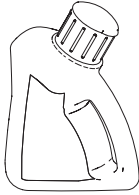

The OroCup care system is a closed dosing system for simple preparation and suctioning of disinfectants and special cleaners.

Use OroCup to clean and disinfect the suction system with all of its components and the spittoon.

7.2 Rinsing unit

In the absence of a spittoon or rinsing unit in the treatment unit, it is absolutely essential that a rinsing unit be installed in the VSA 300 S. In addition, for surgical procedures and for procedures using airflow a rinsing unit must always be installed in the treatment unit to supply a small amount of water to the system during aspiration. Any secretions present will thus be diluted and can be transported away more easily.

For further information, refer to the rinsing unit installation and operating instructions

7.3 Spittoon valve

To ensure that the waste water from the spittoon bowl is directed into the suction pipe, a spittoon valve needs to be installed between the drain of the spittoon bowl and the suction pipe. The spittoon valve must switch on the suction machine if required.

7.4 Flow accelerator

In order to keep the suction system free of deposits, a flow accelerator can be fitted in conjunction with a spittoon valve. When using a bowl rinse system, water will collect before the flow accelerator. The next time suction takes place using the large cannula, the collected fluid is transported in surges and at high speed to the suction system. This ensures automatic cleaning of the suction pipes.

7.5 Exhaust air filter

For hygienic reasons, we recommend the installation of a bacteria filter in the exhaust air line. If the unit is installed in the surgery and the exhaust air cannot be discharged to the outdoors, it is essential to install a bacteria filter. Depending on the type and condition of the bacteria filter, it will need to be replaced every 1-2 years at the latest.



The separation integrated in the system does not retain bacteria; this is why we recommend installing a suitable filter in the exhaust air system.

7.6 Noise reduction

If the noise level from the exhaust air vent or the flow noise generated is too high, noise reduction can be installed in the exhaust air line.

8 Installation



The actual connection can vary depending on the chosen installation option. The connection shown is only an example.

8.1 Installation and routing of hoses and pipes

- Establish connections between the pipe system and the unit using the flexible hoses supplied. This will prevent vibrations from being transmitted to the pipe system.
- The connection between the pipe line and unit suction connection should be kept as short as possible and straight, without bends.
- Install the drain hoses with a downward gradient so that the waste water can drain off.
- Waste water connections must be implemented in accordance with applicable local and national regulations.

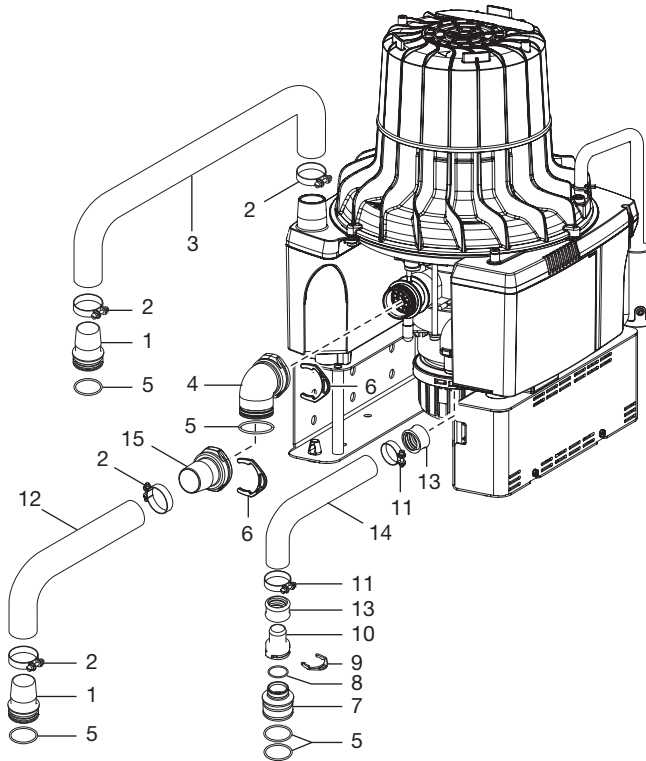

- 1 Hose connector Ø 30 mm
- 2 Hose clip 25-40 mm
- 3 Waste air pipe (aluminium) Ø 30 mm inside
- 4 Elbow DN 30
- 5 O-ring Ø 30x2 mm
- 6 Securing ring
- 7 Connector Ø 36 mm (external)
- 8 O-ring Ø 20x2 mm
- 9 Securing ring
- 10 Hose sleeve Ø 20 mm
- 11 Hose clip Ø 28 mm
- 12 Suction hose Ø 30 mm (internal)
- 13 Hose sleeve
- 14 Waste water hose Ø 20 mm (internal)
- 15 Hose sleeve Ø 30 mm

8.2 Rinsing unit water connections

 Check the water pressure for the rinsing unit. The water pressure should be between 2 and 5 bar.

1. Slide the clamping ring approx. 1.5 cm down the water hose.

 Dürr Dental recommends a water hose with an internal diameter of 2 mm; material: TPU, 87 Shore A, test certificate in accordance with German KTW ("contact with potable water") guideline.

2. Plug the water hose onto the water connector.

3. Use a suitable tool to slide the clamping ring to just before the end of the water hose.

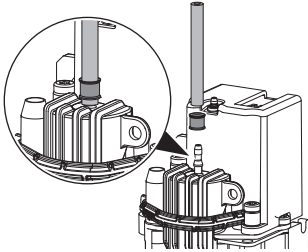

4. Attach a T-piece for the water hose with a diameter of \varnothing 4 mm or \varnothing 6 mm in the water supply.

5. Attach the water hose with the sleeve piece, clamping ring and union nut to the T-piece.

6. Alternatively, attach the water hose with the adapter part, seal, R3/4" screw connection, sleeve piece, double-tapered ring and union nut to a water tap.

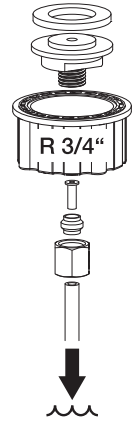
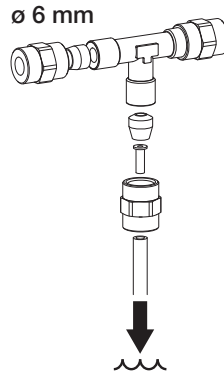

8.3 Electrical connections

1. Connect the control line.
2. Connection the display panel.
3. Connect the network cable (optional when using monitoring software).
4. Establish the electrical connection to the supply network (230 V).

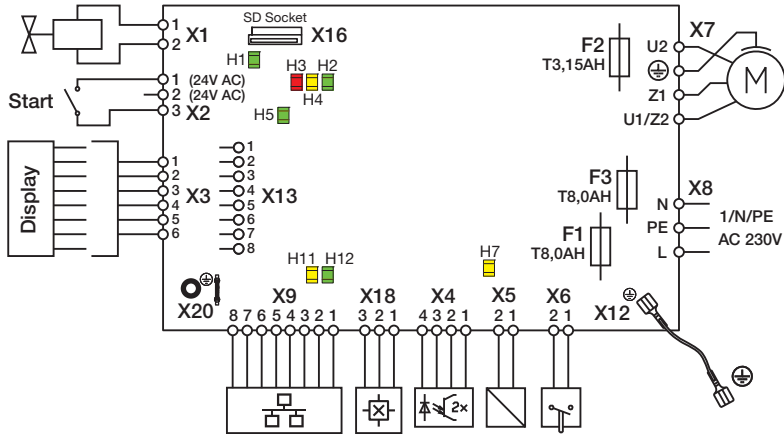

- X1 Voltage supply for the rinsing unit
- X2 24V output voltage and switching contact to suction unit in the treatment unit
- X3 Display panel
- X4 Sediment sensor light barriers
- X5 Sediment sensor lifting magnet
- X6 Collecting container safety switch
- X7 Motor connection
- X8 Mains connection
- X9 Network connection
- X12 Ground contact to the unit housing
- X13 Display panel
- X16 SD card holder (for Micro SD)
- X18 Connection of the hall sensor for monitoring the speed
- X20 Ground contact to the unit housing
- F1 Main fuse
- F2 Brake fuse
- F3 Main fuse
- H1 Rinsing unit
- H2 Display green (as with display panel)
- H3 Display red (as with display panel)
- H4 Display yellow (as with display panel)
- H5 Switching contact control signal suction unit in the treatment unit

H7 Sediment sensor lifting magnet

H11 Network

H12 Network

8.4 Connections and displays of the control

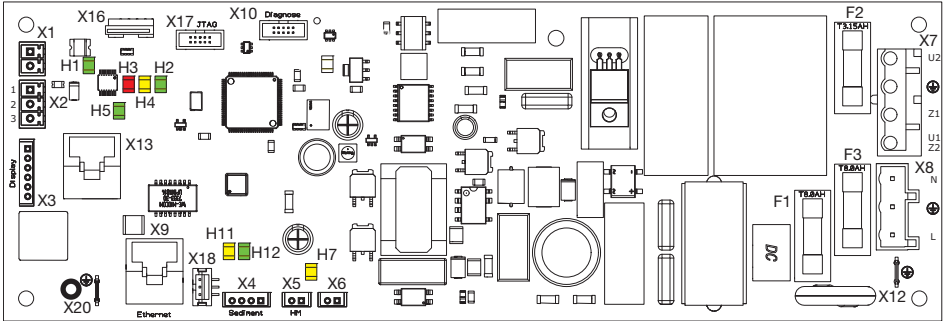

- X1 Voltage supply for the rinsing unit
- X2 24V output voltage and switching contact to suction unit in the treatment unit
- X3 Display panel
- X4 Sediment sensor light barriers
- X5 Sediment sensor lifting magnet
- X6 Collecting container safety switch
- X7 Motor connection
- X8 Mains connection
- X9 Network connection
- X10 Diagnosis
- X12 Ground contact to the unit housing
- X13 Display panel
- X16 SD card holder (for Micro SD)
- X17 JTAG programming interface
- X18 Connection of the hall sensor for monitoring the speed
- X20 Ground contact to the unit housing
- F1 Main fuse
- F2 Brake fuse
- F3 Main fuse
- H1 Rinsing unit
- H2 Display green (as with display panel)
- H3 Display red (as with display panel)
- H4 Display yellow (as with display panel)
- H5 Switching contact control signal suction unit in the treatment unit
- H7 Sediment sensor lifting magnet
- H11 Network
- H12 Network

8.5 Display panel connection

i There must be a direct line connecting the network socket on the unit and the network socket on the display panel. Do not toggle network units (e. g. switch or router).

Observe the resistance of the network cable between the network sockets. The maximum length should not exceed 50 m.

1. Connect the network cable in the network socket to the VSA 300 S in the network bushing (X13).
2. Connect the display panel and network socket using the ISDN cable supplied.

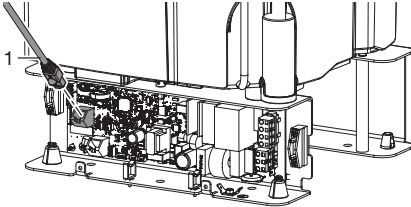

1 Network cable

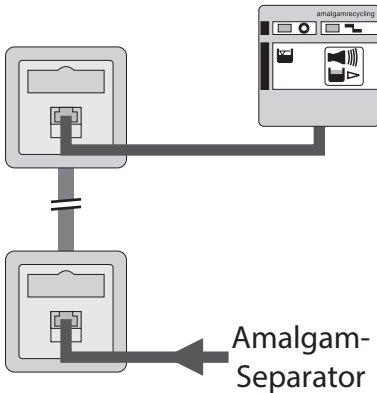

8.6 Network connection

i All connected IT units must correspond to the currently-valid edition of IEC 62368.

Purpose of the network connection

The network connection is used to exchange information or control signals between the unit and a software installed on a computer, in order to, e. g.:

- Display parameters
- Select operating modes
- Indicate messages and error situations
- Change unit settings
- Activate test functions
- Transmit data for archiving
- Provide documents concerning the units

Connecting the device to the network

i During initial installation, a router or server with DHCP is recommended so the unit is detected in the network.

1. Plug in the network cable at the network connection on the unit (optional when using monitoring software).
2. Plug in the network cable at the network socket.

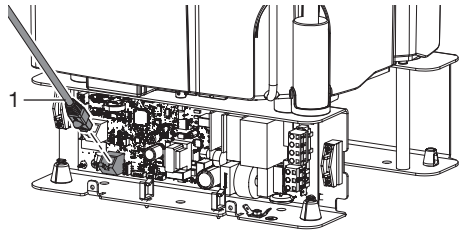

1 Network cable

9 Commissioning

 In many countries technical medical products and electrical devices are subject to regular checks at set intervals. The owner must be instructed accordingly.



NOTICE

Interference caused by larger particles such as pieces of tooth or fillings

› Do not operate the unit without a coarse filter

1. Check that the coarse filters are installed in the suction system (e.g. in the spittoon).
2. Turn on the unit power switch or the main surgery switch.
3. Carry out a function check of the device.
4. Check all connections for leak tightness.
5. Carry out an electrical safety check in accordance with applicable regulations (e.g. regulations concerning set up, operation and application of medical devices) and record the results as appropriate, e.g. in the technical log book.
6. Carry out and document the instruction and handover for the unit.

 A sample handover report is included in the attachment.

9.1 Monitoring the unit via the network

The following requirements must be met in order to monitor the unit on the computer:

- Unit connected to the network
- Current monitoring software installed on the computer

Combining devices safely

- The overall safety of the unit and its main performance features are independent of the network. The device is designed for operation independent of a network. However, some of the functions are not available in this case.
- Incorrect manual configuration can lead to significant network problems. The expert knowledge of a network administrator is required for configuration.
- The data connection utilises part of the bandwidth of the network. Interactions with other medical devices cannot be completely ruled out. Apply the IEC 80001-1 standard for risk assessment.
- The device is not suitable for direct connection to the public Internet.
 1. When connecting the unit to other devices, such as a PC system, comply with the requirements set out in section 16 of IEC 60601-1 (EN 60601-1).
 2. When setting up the PC system in the vicinity of the patients:
Only connect components (e.g. computer, monitor, printer) that comply with the standard IEC 60601-1 (EN 60601-1).
 3. When setting up the PC system outside of the vicinity of the patients:
Connect components (e.g. computer, monitor, printer) that comply at least with the standard IEC 60950-1 (EN 60950-1) at least.

Network configuration

Various options are available for network configuration:

- ✓ Automatic configuration via DHCP (recommended).
- ✓ Automatic configuration via Auto-IP for direct connection of unit and computer.
- ✓ Manual configuration.
 1. Configure the network settings of the unit using the software or, if available, the touch screen.
 2. Check the firewall and release the ports, if applicable.

Network protocols and ports

Port	Purpose	Service
45123 UDP, 45124 UDP	Unit recognition and configuration	

Port	Purpose	Service
1900 UDP	Service indicator	SSDP / UPnP
502 TCP	Unit data	
514 ¹⁾ UDP	Event protocol data	Syslog
22 TCP, 23 TCP	Diagnosis	Telnet, SSH
123 UDP	Time	NTP

¹⁾ The port can vary depending on the configuration.

10 Service program

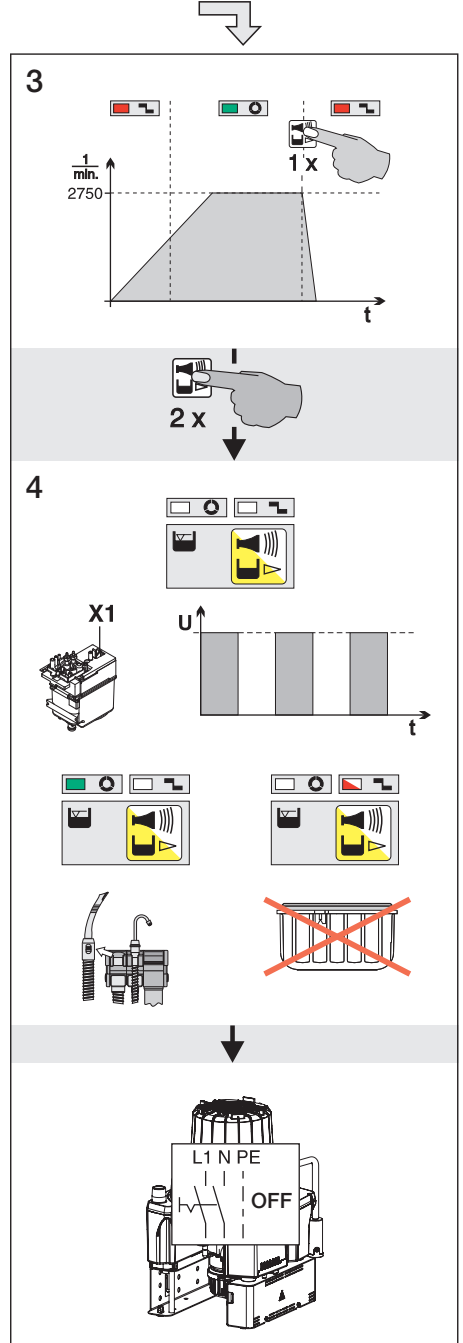
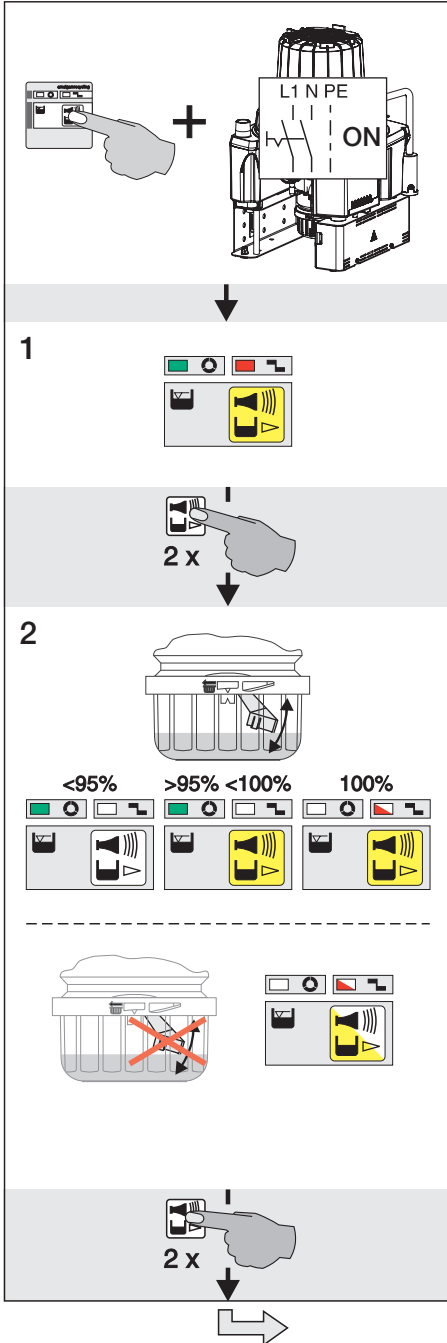

11 Description of the service program



Wear protective equipment to avoid any risk of infection (e.g. liquid-tight protective gloves, protective goggles, face mask).

The various unit functions can be checked with the aid of the service program.

The individual program steps are:

- Display test
- Sediment level measurement
- Motor start and motor braking with rpm check
- Input and output signals

Function of the service key:

- By pressing the service key twice the next individual program step is called up.
- By pressing the service key once that program step is repeated.

A press of the service key is confirmed by an audible signal.

11.1 Service program ON/OFF

On

- Press the service key and switch on the voltage supply to the unit.
- As soon as a signal melody can be heard, release the service key.
The green, yellow and orange LEDs on the display panel light up (display test) and the service program is activated.

Off

Switch off the main supply to the unit.

11.2 Display test

The display test is activated as soon as the service program is started.

The LEDs on the display panel are checked. All three LEDs must come on. There is also an audible signal, which can be switched off by pressing the service button.

11.3 Sediment level measurement



While the service program is activated, the safety check for the collector vessel is deactivated.

The sediment level measurement can be used to check the function of the sediment sensor and the function of the LEDs.

Every time the service key is pressed, the sediment level is checked. If a test container is used, the different 95% and 100% filling level on the display panel can be revealed.

Fill level measurement fault

If no level measurement is carried out due to a fault or defect, the red and yellow displays flash synchronously.

11.4 Motor start - motor braking

The drive motor starts up and is automatically braked after the afterrunning time. If the service key is pressed before the end of the delay time, the motor will immediately be braked.

This procedure can be repeated by pressing the service key 1x again.

As a result of the rpm monitoring, the LED will change from orange to green upon start-up and from green to orange upon braking.

11.5 Input and output signals

- After activating the program point, the yellow LED on the display panel flashes.
- A cycled DC voltage (c. 22-30 V) can be measured on the rinsing unit connection (X1).
- Opening the collecting container causes the red display to flash on the display panel.
- If a start signal is applied to socket X2 (lift out the suction hose on the hose manifold) the green LED illuminates on the display panel.



12 Display/handling

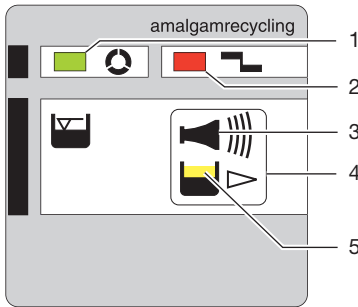

- 1 GREEN LED
- 2 RED display
- 3 Audible signal/melody
- 4 Reset/service key
- 5 YELLOW LED

12.1 Ready for operation

 GREEN LED lights up

12.2 Amalgam collector vessel is 95% full

 Yellow LED lights up

 GREEN LED lights up

 Audible signal melody sounds

- At a fill level of 95%, the signal melody can be switched off by pressing the reset button. The device is then ready for operation again.
- The yellow LED comes on as a reminder that the amalgam collecting container is due to be changed. The level display is repeated every time the unit is switched on at the main power switch.

 We recommend changing the amalgam collecting container when it reaches 95% full.

12.3 Amalgam collector vessel is 100% full

 Yellow LED lights up

 Red display flashes

 Audible signal melody sounds

- At a fill level of 100% the signal melody can no longer be switched off by pressing the reset button.
- The collecting container needs to be replaced.



Wear protective equipment to avoid any risk of infection (e.g. liquid-tight protective gloves, protective goggles, face mask).

- The separator will not be ready for operation again until the amalgam collecting container has been replaced

12.4 Fill level measurement fault

 Red display and

 yellow display flash synchronously

 Audible signal

- Press the reset button briefly to switch off the audible signal. The device is then ready for operation again.
- The red and yellow displays flash as a reminder that the fault needs to be rectified.



If this fault occurs on several consecutive days, the fill level measurement must be checked by a service technician.

12.5 Amalgam collector vessel not in position

 Red display flashes

 Audible signal

- Press the reset button briefly to switch off the audible signal.
- Switch off the device.
- Insert the collecting container.
- Switch on the unit.
- Green LED lights up - "Ready for operation"



If this error message occurs when the collecting container is correctly inserted, this indicates that there is a technical defect - inform your Service Technician.

12.6 Motor fault

 Red display and

 green LED flash alternately

 Audible signal

 Occurs during the start-up of the amalgam separator.

- Press the reset button briefly to switch off the audible signal.
- If the reset button is pressed for longer than 2 seconds the unit can be restarted.

 If this problem happens again on the same day, the amalgam separator will no longer be operational - notify the service technician.

12.7 Brake monitoring

 Red display and

 green LED flash alternately

 Audible signal

 Occurs upon braking action of amalgam separator.

- Press the reset button briefly to switch off the audible signal.
- The amalgam separator is still operational.

 If this problem occurs on several consecutive days, the braking must be checked by a service technician.

13 Disinfection and cleaning

The following tasks are required for the disinfection and cleaning of the suction system:

"13.1 Suctioning water"	After every treatment
"13.2 Disinfection"	Daily in the evening after the end of treatment, With increased workloads, before the midday break and after the end of treatment
"13.3 Cleaning"	Allow to act for at least 2 x per week before the start of treatment or during the midday break Alternatively, 5 x per week, with short reaction times



NOTICE

Device malfunctions or damage due to use of incorrect media

Guarantee claims may become invalid as a result.

- › Do not use any foaming agents such as household cleaning agents or instrument disinfectants.
- › Do not use abrasive cleaners.
- › Do not use agents containing chlorine.
- › Do not use any solvents like acetone.

The following should always be used:

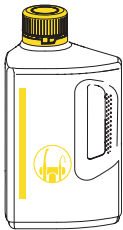

- For disinfection and cleaning:
 - Orotol plus
 - Orotol plus pH 7
- For cleaning:
 - MD 555 cleaner
 - MD 555 cleaner organic

Only these products have been tested by Dürr Dental.



Comply with the instructions for use of the cleaning agent and disinfectant.

13.1 Suctioning water

After every treatment:

1. Suction up cold water (min. 0.5 litres) with the large and small suction hoses. Do this even if only the small suction hose was actually used during treatment.

i Suction through the large suction hose causes a large amount of air to be drawn up, thereby considerably increasing the cleaning effect.

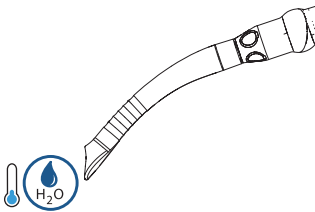



13.2 Disinfection

Disinfect and clean the suction system every evening after the end of treatment.

i With increased workloads, clean and disinfect twice per day, e.g. before the mid-day break and after the end of treatment.

The following is required for the disinfection and cleaning of the suction system:

-  Non-foaming disinfectant/cleaning agent that is compatible with the materials
 - Orotol plus
 - Orotol plus pH 7

-  care system
 - e.g. OroCup

i Disinfection and cleaning are described below with OroCup and Orotol plus.

 Wear protective gloves.

 Wear protective goggles.

1. To pre-clean, suction up 2 litres of water with the care system.



Using the solution in the care system:

1. Pour 2 sealing caps (40 ml) of Orotol plus into the OroCup.

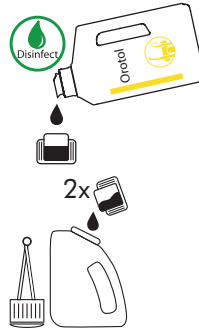

2. Fill the OroCup with 2 litres of cold water.

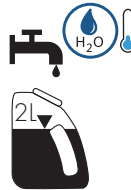

3. Close the lid of the care system.



4. Mix the solution.



Using the solution:

1. Attach suction hoses to the care system and suction up 1 litre of solution.

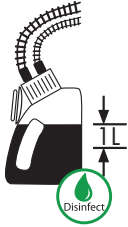

2. Pour the remaining solution into the spittoon.



3. Allow to work for a minimum of one hour or leave overnight.
4. When placing the system back into operation, suction up 2 litres of water.



The instructions are also available as a video:

**13.3 Cleaning**

Clean the suction system regularly:

- Allow to act for at least 2 x per week in the morning before the start of treatment or during the midday break, reaction time 30–120 minutes
- Alternatively: 5 x per week before the start of treatment, reaction time 5–15 minutes

The following is required for cleaning the suction system:



Special non-foaming detergent for suction systems that is compatible with the materials

- MD 555 cleaner
- MD 555 cleaner organic



- care system
- e.g. OroCup



Cleaning is described below with OroCup and MD 555 cleaner.



Wear protective gloves.



Wear protective goggles.

1. To pre-clean, suction up 2 litres of water with the care system.



2. Use the solution in the care system.
Pour 5 caps (100 ml) of MD 555 cleaner into the care system.

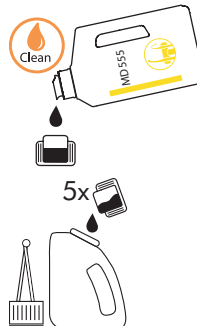

3. Fill the OroCup with 2 litres of cold water.

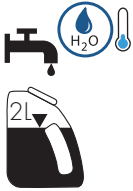

4. Close the lid of the care system.



5. Mix the solution.



6. Attach suction hoses to the care system and suction up one litre of solution.



7. Pour the remaining solution into the spittoon.



8. Allow the solution time to act.
For 2 x per week: 30–120 minutes
For 5 x per week: 5–15 minutes

9. Suction up 2 litres of water after the reaction time has elapsed.



The instructions are also available as a video:



14 Replace the amalgam collector vessel



NOTICE

Risk of contamination if the amalgam collector vessel is reused since the collector vessel is not water-tight.

- › Do not use the collecting container more than once (disposable item).



Wear protective equipment to avoid any risk of infection (e.g. liquid-tight protective gloves, protective goggles, face mask).



We strongly recommend that the amalgam collecting container should only be changed in the morning before the start of work. This will prevent fluid from dripping out of the drum while it is being changed.

1. Disconnect all power from the unit.
2. Remove the full amalgam collecting container and from the device.
3. Pour disinfectant for suction units (e. g. Orotol plus, 30 ml) into the full amalgam collecting container.
4. Close and secure the full amalgam collecting container using the cap. Observe the markings on the cap and on the collecting container.
5. Place the securely closed amalgam collecting container into its original packaging and seal.
6. Insert a new amalgam collecting container in the unit and clamp it in position.



Only use original amalgam collecting container.

7. Switch on the power supply. The unit is ready for operation again.

14.1 Disposal of amalgam collecting container



The contents of the amalgam collecting container are contaminated with heavy metals and must not be disposed of as household waste or the environment.

- Collection and waste disposal by a waste management company specialised in surgery waste.
- Collection and waste disposal by an approved waste management company.

15 Maintenance



All maintenance work must be performed by a qualified expert or by one of our Service Technicians.



WARNING

Infection due to contaminated unit

- › Clean and disinfect the suction before working on the unit.
- › Wear protective equipment when working (e. g. impermeable gloves, protective goggles and mouth and nose protection).



Prior to working on the unit or in case of danger, disconnect it from the mains.

Maintenance interval	Maintenance work
Dependent upon the level of usage of the device	<ul style="list-style-type: none"> › Replace the amalgam collecting container when a fill level of 95% or 100% is indicated on the display panel <p>Notes concerning prophy powders: The function of the amalgam separator is not adversely affected by conventional prophy powders. Under certain circumstances however, increased soiling of lines and hoses and a more frequent changing of the amalgam collecting container can be expected.</p>
Annually	<ul style="list-style-type: none"> › Cleaning of the suction unit in accordance with the operating instructions. › Check the inlet and outlet hoses for signs of deposits/blockage or cracks and replace as required. * › Check the outflow valve and replace as required. * › Replace the exhaust air filter (depending on the installation conditions). *

* to be done by service technicians only

15.1 Intensive cleaning

Intensive cleaning can be carried out during the self-clean process of suction systems that are heavily contaminated with biofilms or if the suction power is greatly reduced.

Carry out this intensive cleaning at least twice a week.

Exposure time: 1 – 2 hours

The following is required for intensive cleaning of the suction system:



Special non-foaming detergent for suction systems that is compatible with the materials

- MD 555 cleaner
- MD 555 cleaner organic



care system
– e.g. OroCup



Cleaning is described below with OroCup and MD 555 cleaner.



Wear protective gloves.



Wear protective goggles.

1. To pre-clean, suction up 2 litres of water with the care system.



2. Use the solution in the care system.
Pour 10 caps (200 ml) of MD 555 cleaner into the care system.

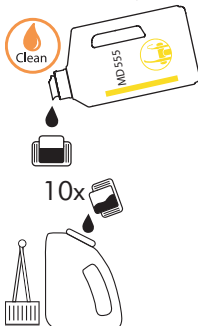

3. Fill the OroCup with 2 litres of cold water.

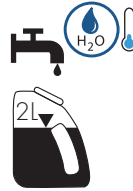

4. Close the lid of the care system.



5. Mix the solution.



6. Attach suction hoses to the care system and suction up one litre of solution.



7. Pour the remaining solution into the spittoon.



8. Allow the solution to act for 1 – 2 hours.

9. Suction up 2 litres of water after the reaction time has elapsed.



15.2 Tests



WARNING

Infection due to contaminated unit

- › Clean and disinfect the suction before working on the unit.
- › Wear protective equipment when working (e. g. impermeable gloves, protective goggles and mouth and nose protection).



In some countries the owner is required to keep an operating handbook. This operating handbook must document all maintenance work, service work, checks and amalgam disposal.

Annual inspection

This inspection should only be carried out by suitably trained staff.

Work steps to be performed:

1. General functional check (e.g. aspiration, spittoon inlet)
2. During the sediment fill level measurement, visually inspect the operability of the sediment sensor.
3. Service program

Device with network connection

This test should be performed as an additional test if the device is monitored with software via the network.

Requirements for the test:

- ✓ Device connected to the network.
- ✓ Monitoring software running.

Work steps to be performed:

1. Check whether any messages are displayed on the PC monitor.
2. Check the acoustic signal.

Inspection of the general operating condition every 5 years

This inspection must be carried out every 5 years (in accordance with the German Waste Water Regulations, Annex 50, Dental Treatment) by an inspector in accordance with national regulations. For inspection, the following are required:

- ✓ Test vessel
- ✓ Measuring beaker

Work steps to be performed:

1. Remove the collector vessel. Here, the red LED on the display panel must flash and an audible signal must sound.
2. Insert the test collector vessel.
3. Press the service key on the display panel.
4. Suck up c. 1 L water.
5. Once the device has switched off, remove the test vessel and measure the remaining amount of water.

The unit is working correctly if:

- there is at minimum content of 70 ml in the test vessel.

If there is less fluid, clean the centrifuge drum or check the operation of the unit.

Troubleshooting

16 Tips for operators and service technicians



Any repairs exceeding routine maintenance may only be carried out by qualified personnel or our service.



WARNING

Infection due to contaminated unit

- › Clean and disinfect the suction before working on the unit.
- › Wear protective equipment when working (e. g. impermeable gloves, protective goggles and mouth and nose protection).



Prior to working on the unit or in case of danger, disconnect it from the mains.

Error	Possible cause	Remedy
Device does not start	No mains voltage	<ul style="list-style-type: none"> › Check the mains supply voltage. * › Check the fuses and replace if necessary. *
	Undervoltage	› Measure the supply voltage; call an electrician if necessary. *
	Control electronics defective	› Replace the electronics. *
Fill level measurement fault	Cable connection to main board not plugged in or interrupted	› Plug in the cable connection to the main board. *
	Sediment sensor coil defective	› Check the coil and replace if necessary. *
	Light barrier defective	› Replace the PCB (main board) with light barriers. *
Motor fault	Rotational speed sensor not working	<ul style="list-style-type: none"> › Check that the Hall sensor is correctly seated. * › Check the plug connections of the sensor cable. * › Check the magnets in the fan wheel. *
The unit generates unusual noises	Solid particles in the turbine chamber	› Disassemble the unit and clean the turbine and housing. *

Error	Possible cause	Remedy
Water leaking from the exhaust air connection	Membrane valve blocked	› Check the membrane valve at the waste water connection and if necessary clean or replace. *
	Foam in turbine due to use of incorrect cleaning and disinfectant agents	› Use non-foaming cleaning and disinfectant agents.
	Build-up of condensate in the exhaust air line	› Check the pipe system; avoid over-cooling. *
	Waste water line/siphon trap blocked	› Clean the waste water line/siphon trap. *
Suction performance too low	Filter blocked	› Clean the filter at the inlet connection.
	Leak in the suction pipe	› Check and if necessary establish leak-tightness of suction pipe and connections. *
	Mechanical sluggishness of turbine caused by soiling	› Disassemble the unit and clean the turbine. *

* Only to be done by service technicians.

17 Transporting the unit



WARNING

Infection due to contaminated unit

- > Disinfect the unit before transport.
- > Close all media connections.



Wear protective equipment to avoid any risk of infection (e.g. liquid-tight protective gloves, protective goggles, face mask).

1. Prior to disassembly, clean and disinfect the suction unit and the unit via aspiration of a suitable disinfectant approved by the manufacturer.
2. Disinfect a defective unit using a suitable surface disinfection agent.
3. Seal all connections with sealing caps.
4. Pack the unit securely in preparation for transport.

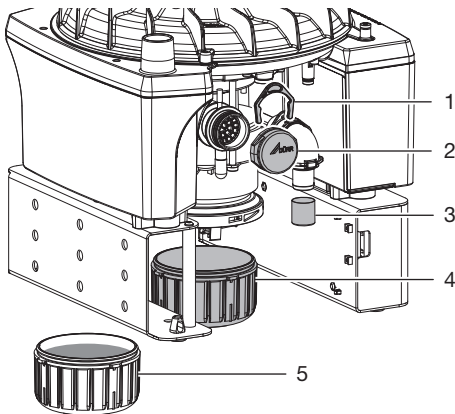

- 1 Securing ring
- 2 Dummy bushing
- 3 Water outflow sealing cap
- 4 Amalgam collecting container EMPTY
- 5 Amalgam collecting container

 Appendix

18 Handover record

This document confirms that a qualified handover of the medical device has taken place and that appropriate instructions have been provided for it. This must be carried out by a qualified adviser for the medical device, who will instruct you in the proper handling and operation of the medical device.

Product name	Order number (REF)	Serial number (SN)

- Visual inspection of the packaging for any damage
- Unpacking the medical device and checking for damage
- Confirmation of the completeness of the delivery
- Instruction in the proper handling and operation of the medical device based on the operating instructions

Notes:

Name of person receiving instruction:

Signature:

Name and address of the qualified adviser for the medical device:

Date of handover:

Signature of the qualified adviser for the medical device:

--	--

19 Country representatives

Country	Address
GB	 <p>UK Responsible Person: Duerr Dental (Products) UK Ltd. 14 Linnell Way Telford Way Industrial Estate Kettering, Northants NN 16 8PS</p>



Hersteller / Manufacturer:

DÜRR DENTAL SE
Höfigheimer Str. 17
74321 Bietigheim-Bissingen
Germany
Fon: +49 7142 705-0
www.duerrdental.com
info@duerrdental.com

