

# Tyscor VS 2 Plus / VS 4



EN Installation and operating instructions

The current version of the installation and operating instructions is available in the Download Center:



<http://qr.duerrdental.com/7188100021>

© 2019-2026 DÜRR DENTAL SE

# Contents



## Important information

|   |   |
|---|---|
| <b>1 About this document</b> . . . . .                      | 3 |
| 1.1 Warnings and symbols . . . . .                          | 3 |
| 1.2 Copyright information . . . . .                         | 4 |
| <b>2 Safety</b> . . . . .                                   | 4 |
| 2.1 Intended purpose . . . . .                              | 4 |
| 2.2 Intended use . . . . .                                  | 4 |
| 2.3 Improper use . . . . .                                  | 4 |
| 2.4 General safety information . . . . .                    | 5 |
| 2.5 Combining devices safely . . . . .                      | 5 |
| 2.6 Specialist personnel . . . . .                          | 5 |
| 2.7 Notification requirement of serious incidents . . . . . | 5 |
| 2.8 Electrical safety . . . . .                             | 5 |
| 2.9 Only use original parts . . . . .                       | 5 |
| 2.10 Transport . . . . .                                    | 6 |
| 2.11 Disposal . . . . .                                     | 6 |
| 2.12 Cybersecurity measures (security context) . . . . .    | 6 |



## Product description

|  |    |
|--|----|
| <b>3 Overview</b> . . . . .                    | 8  |
| 3.1 Scope of delivery . . . . .                | 9  |
| 3.2 Optional items . . . . .                   | 9  |
| 3.3 Consumables . . . . .                      | 9  |
| 3.4 Wear parts and replacement parts . . . . . | 9  |
| <b>4 Technical data</b> . . . . .              | 10 |
| 4.1 Characteristic curves . . . . .            | 12 |
| 4.2 Type plate . . . . .                       | 13 |
| 4.3 Evaluation of conformity . . . . .         | 13 |
| <b>5 Function</b> . . . . .                    | 14 |
| 5.1 Separation system . . . . .                | 15 |
| 5.2 Radial blower . . . . .                    | 15 |
| 5.3 Bacteria filter (optional) . . . . .       | 15 |
| 5.4 LEDs . . . . .                             | 15 |
| 5.5 Touch screen . . . . .                     | 15 |
| 5.6 Operating modes . . . . .                  | 15 |

|   |    |
|---|----|
| 5.7 Boost+ . . . . .                        | 15 |
| 5.8 Quick Start . . . . .                   | 15 |
| 5.9 Lag time . . . . .                      | 15 |
| 5.10 Eco Stop . . . . .                     | 16 |
| 5.11 VistaSoft Monitor (optional) . . . . . | 16 |
| 5.12 Grouping of multiple devices . . . . . | 16 |
| 5.13 OroCup . . . . .                       | 17 |



## Assembly

|  |    |
|--|----|
| <b>6 Requirements</b> . . . . .                            | 18 |
| 6.1 Installation/setup room . . . . .                      | 18 |
| 6.2 Setup options . . . . .                                | 18 |
| 6.3 Pipe materials . . . . .                               | 18 |
| 6.4 Hose materials . . . . .                               | 18 |
| 6.5 Information about electrical connections . . . . .     | 18 |
| 6.6 Information about connecting cables . . . . .          | 18 |
| <b>7 System components</b> . . . . .                       | 19 |
| 7.1 Rinsing unit . . . . .                                 | 19 |
| 7.2 Exhaust air filter / bacteria filter . . . . .         | 19 |
| 7.3 Noise reduction . . . . .                              | 19 |
| 7.4 Surge tank . . . . .                                   | 19 |
| 7.5 Flow accelerator . . . . .                             | 19 |
| <b>8 Installation</b> . . . . .                            | 21 |
| 8.1 Installation and routeing of hoses and pipes . . . . . | 21 |
| 8.2 Installing the group of devices . . . . .              | 22 |
| 8.3 Fitting the rinsing unit . . . . .                     | 22 |
| 8.4 Network connection . . . . .                           | 23 |
| 8.5 CAN bus . . . . .                                      | 23 |
| 8.6 Electrical connections . . . . .                       | 23 |
| 8.7 PCB (main board) electrical connections . . . . .      | 25 |
| 8.8 Testing suction power after installation . . . . .     | 27 |
| <b>9 Commissioning</b> . . . . .                           | 27 |
| 9.1 Setup wizard . . . . .                                 | 27 |
| 9.2 Settings on the touch screen . . . . .                 | 27 |
| 9.3 Monitoring the unit via the network . . . . .          | 30 |



## Usage

|  |    |
|--|----|
| <b>10 Disinfection and cleaning</b> . . . . .                        | 32 |
| 10.1 Suctioning water . . . . .                                      | 33 |
| 10.2 Disinfection . . . . .  | 33 |
| 10.3 Cleaning . . . . .  | 34 |
| <b>11 LEDs</b> . . . . .   | 36 |
| <b>12 Operating the touch screen</b> . . . . .                       | 37 |
| 12.1 Querying messages . . . . .                                     | 37 |
| <b>13 Maintenance</b> . . . . .                                      | 38 |
| 13.1 Wear parts and replacement<br>parts . . . . .                   | 38 |
| 13.2 Clean the filter at the device suc-<br>tion connection. . . . . | 39 |
| 13.3 Confirm maintenance . . . . .                                   | 39 |
| 13.4 Intensive cleaning . . . . .                                    | 39 |



## Troubleshooting

|  |    |
|--|----|
| <b>14 Tips for operators and service techni-<br/>cians</b> . . . . . | 41 |
| 14.1 General faults . . . . .  | 41 |
| 14.2 Fault with Tyscor Tandem Flex . .                               | 44 |
| 14.3 Error messages . . . . .  | 46 |
| <b>15 Transporting the unit</b> . . . . .                            | 49 |



## Appendix

|   |    |
|---|----|
| <b>16 Menu structure</b> . . . . .          | 50 |
| <b>17 Handover record</b> . . . . .         | 52 |
| <b>18 Country representatives</b> . . . . . | 53 |

# Important information

## 1 About this document

These installation and operating instructions represent part of the unit.



The manufacturer and the distributor will not offer any guarantee or accept any liability for the safe operation and the safe functioning of the unit if the instructions and information in these installation and operating instructions are not complied with.

The German version of the installation and operating instructions is the original manual. All other languages are translations of the original manual. These installation and operating instructions apply to:

### **Tyscor VS 2 Plus**

REF: 7188200100

### **Tyscor VS 4**

REF: 7188100100

## 1.1 Warnings and symbols

### Warnings

The warnings in this document are intended to draw your attention to possible injury to persons or damage to machinery.

The following warning symbols are used:



General warning symbol



Warning – dangerous high voltage



Warning - automatic start-up of the unit



Biohazard warning

The warnings are structured as follows:



#### **SIGNAL WORD**

#### **Description of the type and source of danger**

Here you will find the possible consequences of ignoring the warning

- Follow these measures to avoid the danger.

The signal word differentiates between four levels of danger:

- **DANGER**  
Immediate danger of severe injury or death
- **WARNING**  
Possible danger of severe injury or death
- **CAUTION**  
Risk of minor injuries
- **NOTICE**  
Risk of extensive material/property damage

### Other symbols

These symbols are used in the document and on or in the unit:



Note, e.g. specific instructions regarding efficient and cost-effective use of the unit.



Product for the disinfection and cleaning of suction units



Wear protective gloves.



Disconnect all power from the unit.



Refer to the accompanying electronic documents.



Comply with the lower and upper temperature limits



Comply with the lower and upper humidity limits



CE labelling with the number of the notified body



Ukrainian conformity mark with registration number



Authorised representative for Switzerland



Order number



Serial number



Medical device



Health Industry Bar Code (HIBC)



Manufacturer



Fragile, handle with care



This way up / store and transport in an upright position



Keep dry



Keep away from sunlight



Stacking limits

## 1.2 Copyright information

All circuits, processes, names, software programs and units mentioned in this document are protected by copyright.

The Installation and Operating Instructions must not be copied or reprinted, neither in full nor in part, without written authorisation from the copyright owner.

## 2 Safety

The unit has been developed and designed in such a way that dangers are effectively ruled out if used in accordance with the Intended Use. Despite this, the following residual risks can remain:

- Personal injury due to incorrect use/misuse
- Personal injury due to mechanical effects
- Personal injury due to electrical shock
- Personal injury due to radiation
- Personal injury due to fire
- Personal injury due to thermal effects on skin
- Personal injury due to lack of hygiene, e.g. infection

### 2.1 Intended purpose

The suction unit provides the dental treatment unit with vacuum and volume flow.

### 2.2 Intended use

Working in combination with the suction unit with treatment unit, suction handpiece and cannula, the media used in dental treatment (e.g. water, saliva, dentine and amalgam) are removed by suction for disposal.

This unit is technically suitable for the aspiration of nitrous oxide (laughing gas). However, when assembling a system for aspiration of nitrous oxide, it is important to ensure that the other components in the system are also suitable for this purpose. Those responsible for setting up the system must assess this and approve and release the system for the aspiration of nitrous oxide.



Operation with nitrous oxide is only permitted if the exhaust air is transported from the unit to the outside of the building.

### 2.3 Improper use

- Do not use this device to aspirate flammable or explosive mixtures.
- Do not use the unit as a vacuum cleaner.
- Do not use chemicals containing chlorine or foaming chemicals.
- Operation in operating theatres of explosive areas is not permissible.
- The suction unit must not be set up in the immediate surroundings of the patient (minimum distance: 1.5 m).

## 2.4 General safety information

- Always comply with the specifications of all guidelines, laws, and other rules and regulations applicable at the site of operation for the operation of this unit.
- Check the function and condition of the unit prior to every use.
- Do not convert or modify the unit.
- Comply with the specifications of the Installation and Operating Instructions.
- The Installation and Operating Instructions must be accessible to all operators of the unit at all times.

## 2.5 Combining devices safely

Take care when connecting units together or to parts of other systems as there is always an element of risk (e.g. due to leakage currents).

- Only connect units when there can be no question of danger to operator or to patient.
- Only connect units when it is safe to do so and when there is no risk of damage or harm to the surroundings.
- If it is not completely clear from the data sheet of the unit that such connections can be safely made or if you are in any doubt, always get a suitably qualified person (e.g. the relevant manufacturer) to verify that the setup is safe.

Where applicable, the requirements for medical products have been taken into account in the development and construction of the device. As a result, this device is suitable for installation within medical supply equipment.

- Where this device is integrated in other medical supply equipment, the requirements of European Union Medical Device Regulation 2017/745 and the relevant standards must be observed.

## 2.6 Specialist personnel

### Operation

Unit operating personnel must ensure safe and correct handling based on their training and knowledge.

- Instruct or have every operator instructed in handling the unit.

### The following groups are not permitted to operate or use a commercially operated unit:

- People without the necessary experience and knowledge
- People with reduced physical, sensory or mental capabilities
- Children

### Installation and repairs

- The manufacturer recommends that installation, readjustments, alterations, upgrades and repairs be carried out either by the manufacturer itself or by a qualified specialist authorised by the manufacturer.

## 2.7 Notification requirement of serious incidents

The operator/patient is required to report any serious incident that occurs in connection with the device to the manufacturer and to the competent authority of the Member State in which the operator and/or patient is established/resident.



Notify the manufacturer of any serious incidents under the following email address: [incidents@duerrdental.com](mailto:incidents@duerrdental.com).

## 2.8 Electrical safety

- Comply with all the relevant electrical safety regulations when working on the unit.
- Never touch the patient and unshielded plug connections on the unit at the same time.
- Replace any damaged cables or plugs immediately.

## 2.9 Only use original parts

- Only use accessories and optional articles named or authorised by the manufacturer.
- Only use only original wear parts and replacement parts.

**i** The manufacturer and distributor accept no liability for damages or injury resulting from the use of non-approved accessories, optional accessories, or from the use of non-original wear parts or replacement parts.

The use of non-approved accessories, optional accessories or non-genuine wear parts / replacement parts (e.g. mains cables) can have a negative effect in terms of electrical safety and EMC.

## 2.10 Transport

The original packaging provides optimum protection for the unit during transportation.

If required, the original packaging for the unit can be ordered.

**i** The manufacturer and the distributor do not accept liability, even during the warranty period, for damage during transportation due to improper packaging.

- Only transport the unit in its original packaging.
- Keep the packing materials out of the reach of children.

## 2.11 Disposal

**i** The unit may be contaminated. Instruct the company disposing of the waste to take the relevant safety precautions.

- Decontaminate potentially contaminated parts before disposing of them.
- Uncontaminated parts (e.g. electronics, plastic and metal parts etc.) should be disposed of in accordance with the local waste disposal regulations.
- If you have any questions about the correct disposal of parts, please contact your dental trade supplier.

**i** An overview of the waste keys for Dürr Dental products can be found in the download area:



<http://qr.duerrdental.com/P007100155>

## 2.12 Cybersecurity measures (security context)

The device is connected to an IT network that can be connected to the Internet.

Therefore, the security context, which is a shared responsibility between the manufacturer and operator in terms of cybersecurity, must be taken into account.

The following **administrative measures** are required:

- Train employees in security and data protection.
- Appoint a data protection officer.
- Appoint a medical IT risk manager.  
Use of the IEC 80001-1 standard is recommended to manage security risks for medical IT networks.

The configuration of a medical IT network requires the expertise of a network administrator. The following changes to a medical IT network can create new security risks that require a reassessment of the risk analysis:

- Changes to the IT network configuration
- Adding components (hardware or software) to the medical IT network
- Removing components from the medical IT network
- Updating or modernizing components in the medical IT network

**i** Report cybersecurity incidents to the manufacturer at [incidents@duerrdental.com](mailto:incidents@duerrdental.com).

The following **technical measures** must be taken by the operator in order to use the device safely:

- Protect the medical IT network with a firewall and antivirus software.
- Look for evidence of possible virus infection and, if applicable, check with the antivirus software and remove the virus.
- Always keep the software used up to date and make sure you are working with the latest version, particularly with regard to the operating system, firewall and antivirus software.
- Download software or firmware only from trusted sites (e.g. the manufacturer).
- Segment the medical IT network to an extent that makes sense.
- Secure hardware against unauthorized access (IT network, server and connected devices).



For more information, see  
“Cybersecurity White Paper”.  
[http://qr.duerdental.com/  
2110100055](http://qr.duerdental.com/2110100055)

## Product description

### 3 Overview

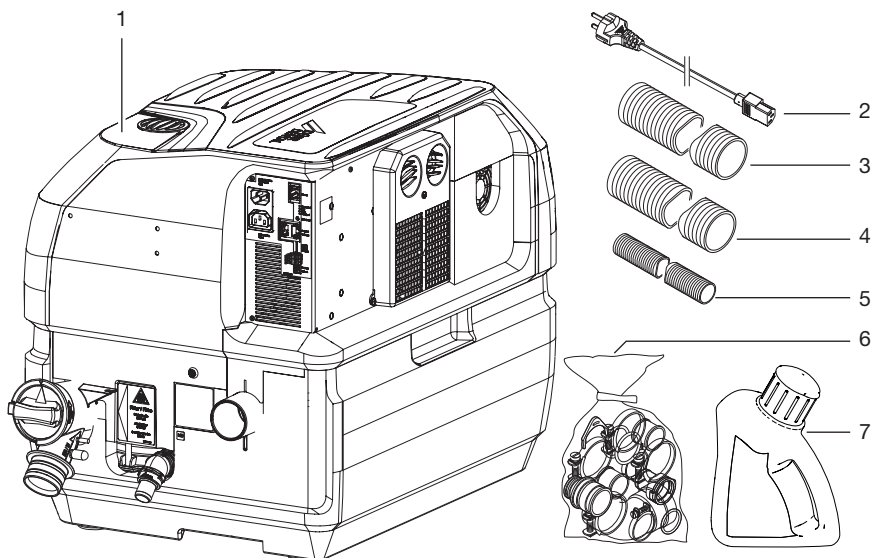

- 1 Combination suction unit
- 2 Mains cable with local mains plug
- 3 Hose LW 50, 1.5 m
- 4 Hose LW 50, 0.6 m
- 5 Waste water hose LW 20
- 6 Set of connection fittings
- 7 OroCup

### 3.1 Scope of delivery

The following items are included in the scope of delivery (possible variant-specific deviations due to country-specific requirements and/or import regulations):

- Tyscor VS 4 . . . . . 7188100100
- Tyscor VS 2 Plus . . . . . 7188200100
- Combination suction unit
- Mains cable
- Hose LW 50 (0.6 m)
- Hose LW 50 (1.5 m)
- Waste water hose LW 20
- Set of connection fittings
- OroCup
- Short information

### 3.2 Optional items

The following optional items can be used with the device:

- Wall bracket . . . . . 7188100015
- Bracket for floor-mounted installation . . . . . 7188100017
- Bacteria filter . . . . . 0705-991-50
- Noise reduction for exhaust air . . . . . 0730-991-00
- Flow accelerator . . . . . 7560-992-00
- Screed frame for flow accelerator . . . . . 7560-993-00
- Surge tank . . . . . 7130-991-51
- Radial blower . . . . . 7188100060
- Rinsing unit conversion kit for Tyscor . . . . . 7186100400
- Upgrade hit V/V/S 2 Plus to V/V/S 4 . . . . . 7188100075
- Installation set for Tyscor V/V/S Tandem . . . . . 7188100300
- Tyscor Tandem Flex installation kit . . . . . 7188100302
- Tyscor Tandem Flex / VS 600 installation kit (up to build year 03/2022) . . . . . 7188100303
- Suction flow measuring device . . . . . 0700-060-51

### 3.3 Consumables

The following materials are consumed during operation of the device and must be ordered separately:

- Orotol plus (2.5 litre bottle) . . . . . CDS110P6150
- Orotol plus pH 7 (2.5-litre bottle) . . . . . CDS117A6150
- MD 555 cleaner (2.5 litre bottle) . . . . . CCS555C6150
- MD 555 cleaner organic (2.5-litre bottle) . . . . . CCS556A6150

### 3.4 Wear parts and replacement parts

The following working parts need to be changed at regular intervals (refer to the "Maintenance" section):

- Nonreturn valve (pack of 3) . . . . . 7128-100-03E
- Backflow preventer valve (pack of 2) . . . . . 7188100082



Information about replacement parts can be found on the website portal for specialist dealers under:  
[www.duerrdental.net](http://www.duerrdental.net)



If the mains cable of this unit is damaged it must only be replaced by an original mains cable from the manufacturer.

## 4 Technical data

| Electrical data    |    | 7188100100                             | 7188200100 |
|--------------------|----|--|------------|
| Rated voltage      | V  | 230, 1~                                | 230, 1~    |
| Mains frequency    | Hz | 50 / 60                                | 50 / 60    |
| Nominal current    | A  |  | 7.2        |
| Active power       | kW |  | 1.6        |
| Fuses              |    | 2x T 10.0 AH / 250 V~<br>(IEC 60127-2) |            |
| Type of protection |    | IP 21                                  |            |
| Protection class   |    | I                                      |            |

| Control connection electrical data |      |       |
|------------------------------------|------|-------|
| Output:                            |      |       |
| Voltage                            | V DC | 24    |
| Max. current                       | mA   | 160   |
| Input impedance                    | kΩ   | 6.9   |
| Hi level                           | V    | 10-30 |
| Lo level                           | V    | 0-2.5 |

| Electrical data for connection of the rinsing unit |      |     |
|--|------|-----|
| Voltage  | V DC | 24  |
| Max. current                                       | mA   | 300 |

| Connections                       |    |      |
|-----------------------------------|----|------|
| Vacuum connection (external)      | mm | Ø 50 |
| Exhaust air connection (external) | mm | Ø 50 |
| Waste connections (DürrConnect)   | mm | Ø 20 |

| Media                       |       |   |    |
|-----------------------------|-------|---|----|
| Max. number of users        |       | 4 | 2  |
| Max. rate of flow of fluids | l/min |   | 20 |
| Max. suction height         | cm    |   | 80 |

| General data                       |                        |              |         |
|------------------------------------|------------------------|--------------|---------|
| Radial blower speed ( $n_v$ ) max. | At least <sup>-1</sup> | 26000        |         |
| Separation stage speed ( $n_s$ )   | At least <sup>-1</sup> | 2780 / 3170  |         |
| Duty cycle                         | %                      | 100          |         |
| Heat generation rate               | MJ/h                   | 5.76         |         |
| Dimensions (H x W x D)             | cm                     | 51 x 45 x 69 |         |
| Weight                             | kg                     | 24           | 24      |
| Sound pressure level * approx.     | dB(A)                  | 57 / 61      | 57 / 61 |

**General data**

\* Sound pressure level in accordance with ISO 3744

**Network connection**

|                    |        |             |
|--------------------|--------|-------------|
| LAN technology     |        | Ethernet    |
| Standard           |        | IEEE 802.3u |
| Data rate          | Mbit/s | 100         |
| Connector          |        | RJ45        |
| Type of connection |        | Auto MDI-X  |
| Cable type         |        | ≥ CAT5      |

**Ambient conditions during storage and transport**

|                   |    |            |
|-------------------|----|------------|
| Temperature       | °C | -10 to +60 |
| Relative humidity | %  | < 95       |

**Ambient conditions during operation**

|                               |    |            |
|-------------------------------|----|------------|
| Temperature                   | °C | +10 to +40 |
| Relative humidity             | %  | < 70       |
| Altitude above mean sea level | m  | < 2000     |

**Classification**

|                            |  |     |
|----------------------------|--|-----|
| Medical Device Class (MDR) |  | Ila |
|----------------------------|--|-----|

**Classification in accordance with EN ISO 10637**

|  |  |                         |
|--|--|-------------------------|
| Classification based on separation of solids and liquids |  | Semi-dry suction system |
| Classification based on flow rate                        |  | Type 1                  |

## 4.1 Characteristic curves

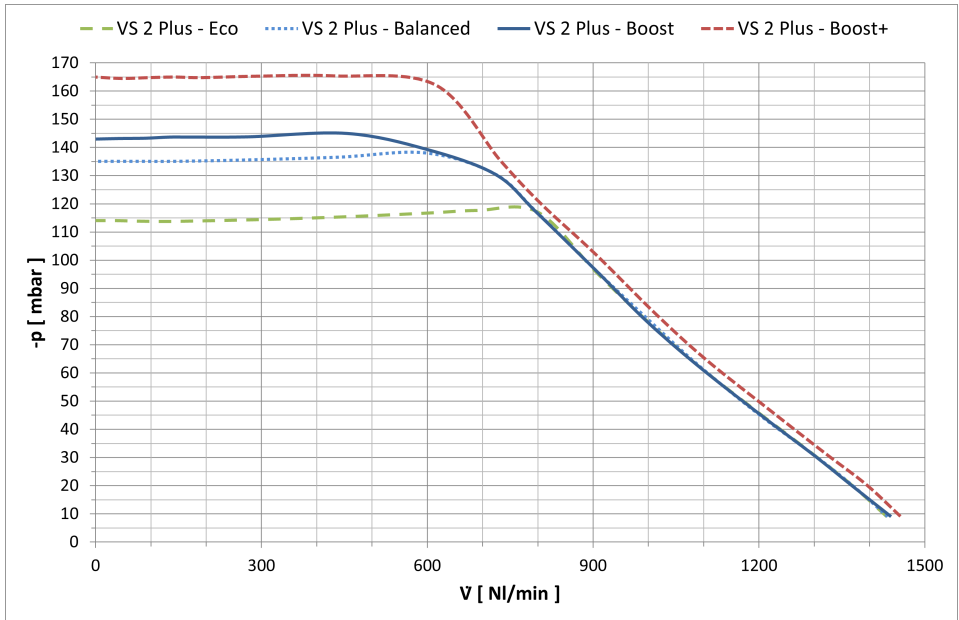

Fig. 1: Characteristic curves for 7188200100, measured in accordance with ISO 10637

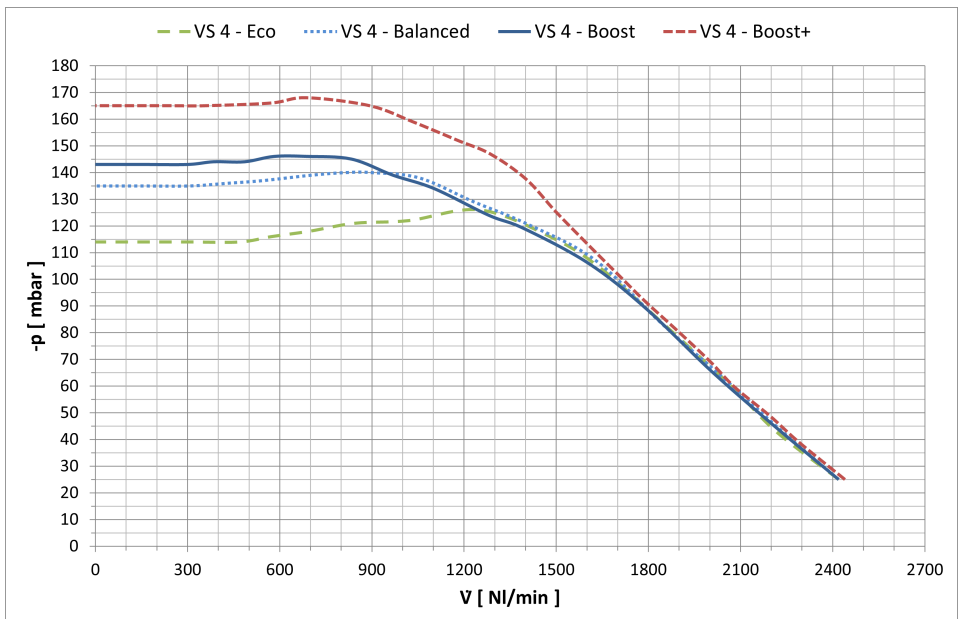
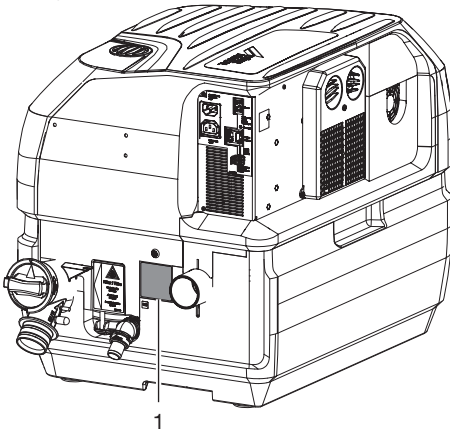

Fig. 2: Characteristic curves for 7188100100, measured in accordance with ISO 10637

## 4.2 Type plate

The type plate can be found on the housing lower part.



1 Type plate

## 4.3 Evaluation of conformity

This device has been subjected to conformity acceptance testing in accordance with the current relevant European Union guidelines. This equipment conforms to all relevant requirements.

## 5 Function

When treating their patients with dental instruments, dentists, dental assistants and hygienists all face increased exposure to infectious aerosols and droplets. Studies have shown that intraoral spray mist extraction can effectively eliminate these aerosols and droplets. According to one study, a flow rate of at least 300 l/min reduces particle emissions when using a turbine to below the limit of detection (study by Koch & Graetz).

In order to achieve this volume flow at the suction cannula, a type 1 suction unit (in accordance with DIN EN ISO 10637) with an air volume flow of at least 250 NL/min is required.

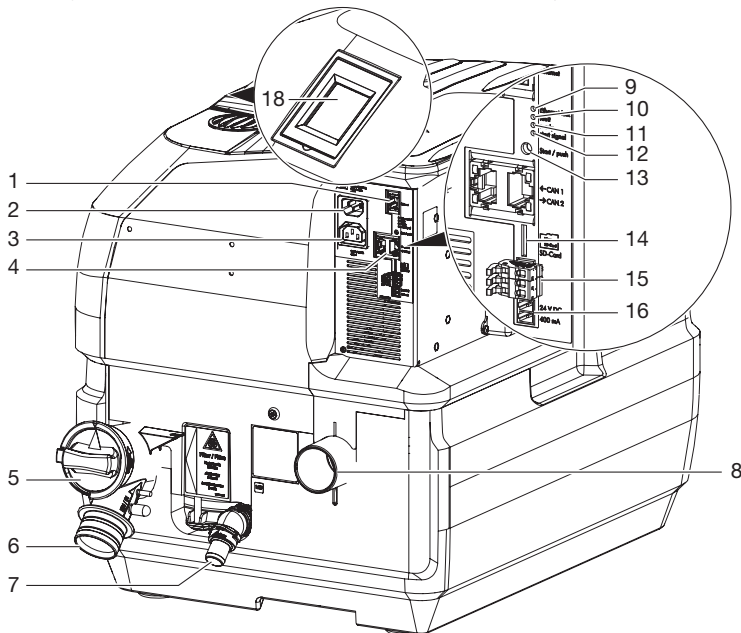

- |   |   |    |                                     |
|---|---|----|-------------------------------------|
| 1 | Network connection                                      | 9  | Orange LED – Ethernet               |
| 2 | Mains connection (power plug)                           | 10 | Red LED – fault                     |
| 3 | Connection to amalgam separator (appliance power inlet) | 11 | Green LED – ready for operation     |
| 4 | CAN bus   | 12 | Blue LED – start signal             |
| 5 | Filter at the device suction connection                 | 13 | Manual start button                 |
| 6 | Intake connector  | 14 | SD card slot (Micro SD)             |
| 7 | Waste water connection                                  | 15 | Control connection                  |
| 8 | Exhaust air connection                                  | 16 | Voltage supply for the rinsing unit |
|   |   | 18 | Touch screen                        |

The suction machine is a combination suction unit that is used in “wet” suction systems and consists of a separation system and a suction unit with two radial blowers. These are each driven by their own motors. The suction unit is switched on when a suction hose is removed from the hose manifold.

With the optional upgrade kit, the Tyscor VS 2 Plus can be upgraded to the Tyscor VS 4 to support up to four practitioners.

## 5.1 Separation system

In the separation system the aspirated fluids and the solid particles are separated from the suction air.

The waste water pump in the separation system feeds the fluid together with the finer solid particles through the waste water system connection into the central waste water network.

The speed of the separation system is continuously monitored to detect increased contamination or flooding. If the speed falls below a minimum level, the centrifugal blowers are deactivated before a fault can occur.

## 5.2 Radial blower

The air that has been separated from the fluids is sucked into the radial blowers. The motors in the radial blowers are regulated on a demand-driven basis by the unit electronics. Afterwards, the aspirated air is passed through the exhaust air connections and out of the device.

The antibacterial treatment of the surfaces of the radial blower with silver phosphate glass helps impede the growth of bacteria for a hygienic surface of the components.

## 5.3 Bacteria filter (optional)

The optional exhaust air bacteria filter reduces particles and microorganisms from the exhaust air.

For hygienic reasons, we recommend the installation of a bacteria filter in the exhaust air line.



If the device is installed in the dental practice and the exhaust air cannot be discharged to the outdoors, a bacteria filter must be installed.

## 5.4 LEDs

The LEDs show the status of the device:

- Operating status (ready for operation or Eco-Stop)
- Start signal of the treatment unit
- Network connection
- Fault

## 5.5 Touch screen

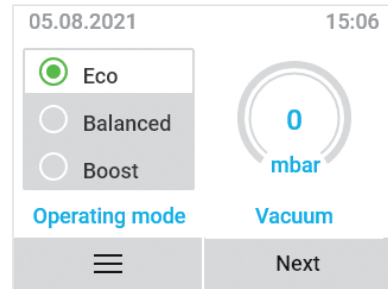

The touch screen shows the current status along with messages on the device.

Configuration is also carried out on the touchscreen.

## 5.6 Operating modes

Four different operating modes are available for Tyscor V/VS 2 Plus and Tyscor V/VS 4. These can be set up on the touch screen. If you are using monitoring software then you can also change the settings there.

The operating modes are "Eco", "Balanced", "Boost" and "Boost+". The different operating modes can be used to adjust the available power to the suction system (routing of lines, line lengths, layout of treatment unit etc.).

## 5.7 Boost+

The Boost+ function increases the maximum possible vacuum. If a higher vacuum is needed for a particular application, Boost+ can be activated in order to make the "Boost+" operating mode available for selection.

## 5.8 Quick Start

The Quick Start function is used to hold the unit in standby mode for a certain length of time, which ensures fast availability of the suction flow when required. Since the motor remains switched on at a very low speed when the unit is in standby mode, this option consumes slightly more energy.

## 5.9 Lag time

The device will continue to run for a few seconds after the suction hose has been hung back in the manifold. The lag time ensures that the remaining fluid in the suction system can be processed. Depending on the installation, the lag time can be adjusted accordingly.

## 5.10 Eco Stop

The Eco Stop function is used to protect the unit if it is operated inadvertently with no flow rate or with a flow rate that is too low. If the unit is operated under these conditions without the manifold signal being actuated in the mean time, the unit will switch off automatically after a pre-defined period of time (it is possible to set this up so that it can be adjusted via the monitoring software). To switch it on, lift a suction hose up out of the hose manifold or briefly disconnect the power supply from the unit.

## 5.11 VistaSoft Monitor (optional)

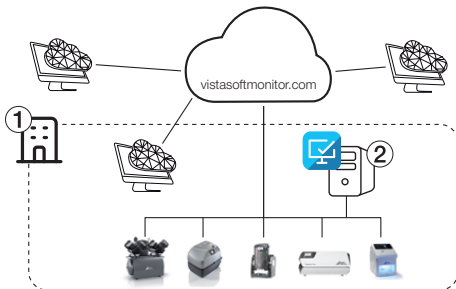

- 1 Local practice network
- 2 Computer in the local network with server installation

The device can be connected to the VistaSoft Monitor monitoring software via the local practice network.

The software displays the device's messages, current status and upcoming maintenance. The information can be viewed on the computer in the practice or via the cloud.

## 5.12 Grouping of multiple devices

By combining multiple devices together in this way, the available volume flow can be increased, which in turn means that the maximum number of therapists can use the system.

Up to three Tyscor suction machines can be connected together with the *installation set for Tyscor V/VS Tandem*.

The *installation set for Tyscor Tandem Flex* is required to combine a Tyscor suction unit with a side channel suction unit.

See also "3.2 Optional items".

### Tyscor Tandem: Combination of several Tyscor suction units

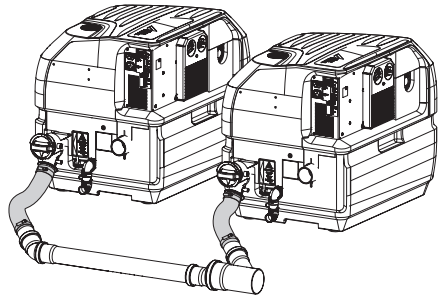

Up to three Tyscor Suction Machines can be operated together as a group. Here, one device takes on the role of the controller (main unit) and controls up to two additional devices (auxiliary units).

**i** When grouped together, mutual controlling and exchange of information takes place via the CAN bus. Only one device is permitted to be configured as the main unit; additional devices must be configured as auxiliary units.

### Tyscor Tandem Flex: Combination of one Tyscor with a side channel suction unit

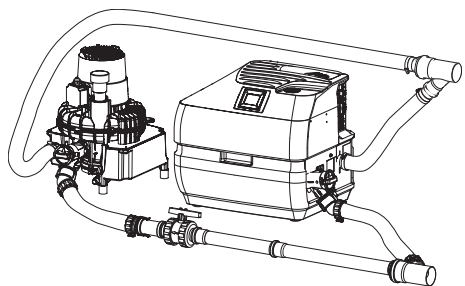

The Tyscor suction unit can be operated in combination with a side channel suction unit. The Tyscor monitors the vacuum in the suction line and switches itself on and off automatically as required. It thus serves to extend the side channel suction unit.

In this constellation, only the "Balanced" and "Boost" operating modes are available.

## 5.13 OroCup

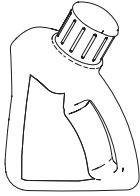

The OroCup care system is a closed dosing system for simple preparation and suctioning of disinfectants and special cleaners.

Use OroCup to clean and disinfect the suction system with all of its components and the spittoon.

# Assembly

## 6 Requirements

The unit can be installed on the same level as the surgery room or in a floor below.

 Further information can be found in the planning information leaflet for suction, available separately.

### 6.1 Installation/setup room

The room chosen for set up must fulfill the following requirements:

- Closed, dry, well-ventilated room
- Should not be a room made for another purpose (e. g. boiler room or wet cell)
- When installing in a cabinet the inlet and outlet ventilation slots must be present; minimum free cross-section at least 120 cm<sup>2</sup>.
- Forced ventilation (fan) must be provided if there is a risk that the recommended room air temperature could be exceeded. The air flow performance must be at least 2 m<sup>3</sup>/min.
- Do not cover cooling slots or openings with housing installations; ensure sufficient clearance to the openings to permit sufficient cooling.
- Mains cable plug connections must be freely accessible so they can be quickly disconnected if there is any danger.

### 6.2 Setup options

The following options for setting up the unit are available:

- On the floor with a console for floor-mounted installation
- Wall installation using a Dürr Dental wall mounting
- In a ventilated cabinet

### 6.3 Pipe materials

**Only use vacuum-sealed HT-waste pipes manufactured from the following materials:**

- Polypropylene (PP),
- Chlorinated polyvinyl chloride (PVC-C),
- Plasticizer-free polyvinyl chloride (PVC-U),
- Polyethylene (PE).

**The following materials must not be used:**

- Acrylonitrile-butadiene-styrene (ABS),
- Styrene copolymer blends (e.g. SAN + PVC).

### 6.4 Hose materials

**For waste connections and suction lines only use the following hose types:**

- Flexible spiral hoses made of PVC with integrated spiral or equivalent hoses
- Hoses that are resistant to dental disinfectants and chemicals

 Plastic hoses will display signs of ageing over time. Therefore, they should be inspected regularly and replaced as necessary.

**The following types of hoses must not be used:**

- Rubber hoses
- Hoses made completely of PVC
- Hoses that are not sufficiently flexible

### 6.5 Information about electrical connections

- Ensure that the electrical connections to the mains power supply are established in accordance with current valid national and local regulations and standards governing the installation of low voltage units in medical facilities.
- Observe the current consumption of the devices that are to be connected.

### 6.6 Information about connecting cables

#### Mains supply cable

Only use the supplied mains cable to connect the device.

#### Control cable

| Installation type  | Line layout (minimum requirements)            |
|--------------------|---|
| Fixed installation | - Shielded sheathed cable (e.g. (N)YM (St)-J) |

| Installation type | Line layout (minimum requirements)  |
|-------------------|---|
| Flexible          | <ul style="list-style-type: none"> <li data-bbox="294 172 542 323">– PVC data cable with shielded cable sheathing, as used for telecommunications and IT processing systems (e.g. type LIYCY)</li> <li data-bbox="294 331 314 352">or</li> <li data-bbox="294 360 542 427">– Lightweight PVC control cable with shielded cable sheathing</li> </ul> |



Connect the shielding of the cables in accordance with the regulations.

## 7 System components

The system components listed below are required or recommended for various procedures or for installation.

### 7.1 Rinsing unit

It is recommended that the suction system is equipped with a rinsing unit, e.g. in the treatment unit. The rinsing unit provides a small amount of water during aspiration. This dilutes the aspirated fluids (blood, saliva, rinsing water etc.), which can then be transported more effectively.

### 7.2 Exhaust air filter / bacteria filter

For hygienic reasons, we recommend the installation of a bacteria filter in the exhaust air line. If the unit is installed in the surgery and the exhaust air cannot be discharged to the outdoors, it is essential to install a bacteria filter. Depending on the type and condition of the bacteria filter, it will need to be replaced every 1-2 years at the latest.



The separation integrated in the system does not retain bacteria; this is why we recommend installing a suitable filter in the exhaust air system.

### 7.3 Noise reduction

If the noise level from the exhaust air vent or the flow noise generated is too high, noise reduction can be installed in the exhaust air line.

### 7.4 Surge tank

If the suction unit is combined with an amalgam separator, this requires the installation of a surge tank. The surge tank reduces pressure peaks caused by the waste water pump of the suction unit and acts as a buffer against temporary rises in the volume of water.

The surge tank can also be used if the waste water is fed directly into the building waste water system. In this case the waste water from the suction unit is diverted to the building drainage system under zero pressure.

### 7.5 Flow accelerator

In order to keep the suction system free of deposits, a flow accelerator can be fitted in conjunction with a spittoon valve. When using a bowl rinse system, water will collect before the flow

accelerator. The next time suction takes place using the large cannula, the collected fluid is transported in surges and at high speed to the suction system. This ensures automatic cleaning of the suction pipes.

## 8 Installation



The actual connection can vary depending on the chosen installation option. The connection shown is only an example.

### 8.1 Installation and routing of hoses and pipes

- Establish connections between the pipe system and the unit using the flexible hoses supplied. This will prevent vibrations from being transmitted to the pipe system.
- The connection between the pipe line and unit suction connection should be kept as short as possible and straight, without bends.
- Install the drain hoses with a downward gradient so that the waste water can drain off.
- Waste water connections must be implemented in accordance with applicable local and national regulations.

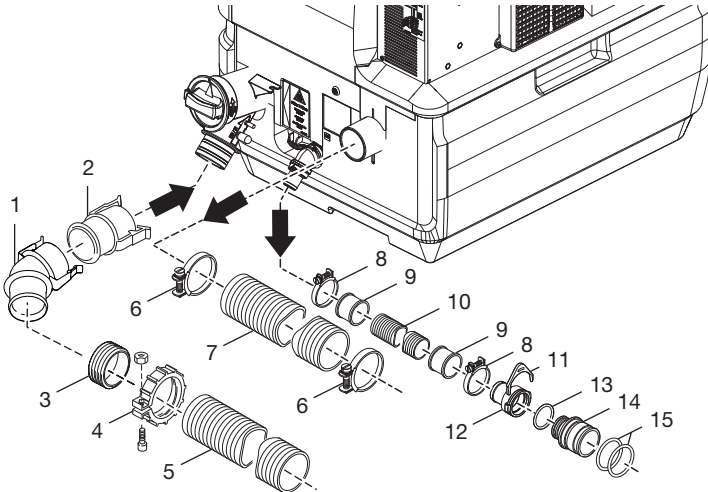

- 1 Curved adaptor bush
- 2 Straight adaptor bush
- 3 Sealing sleeve
- 4 Union nut
- 5 Suction hose  $\varnothing$  50 mm (internal)
- 6 Hose clamp  $\varnothing$  55 mm
- 7 Exhaust air hose  $\varnothing$  50 mm (internal)
- 8 Hose clip  $\varnothing$  28 mm
- 9 Hose sleeve
- 10 Waste water hose  $\varnothing$  20 mm (internal)
- 11 Securing ring
- 12 Hose sleeve  $\varnothing$  20 mm
- 13 O-ring 20 x 2.0
- 14 Connector  $\varnothing$  36 mm (external)
- 15 O-ring 30 x 2

## 8.2 Installing the group of devices

Various mounting kits are available for installing several devices in a device network (see also "3.2 Optional items"):

- *Installation set for Tyscor V/VS Tandem* for the combination of up to three Tyscor suction machines
- *Installation set for Tyscor Tandem Flex* mounting kit for combining a suction unit with a Tyscor side channel suction machine

The installation sets contain various parts (pipes, fittings, hose clamps, etc.) and corresponding installation information.

 Setup and installation must be carried out in accordance with the requirements of Dürr Dental. Corresponding installation information is enclosed with the installation set but can also be downloaded from the Dürr Dental homepage.

The *installation set for Tyscor Tandem Flex / VS 600 (up to production date 03/2022)* is also required for connection to a side channel suction unit VS 600.

 All suction units in the group must be on the same level, and the supply manifold must be at least 5 cm lower than the suction inputs.

## 8.3 Fitting the rinsing unit

1. Securely screw the rinsing unit onto the retaining plate.
2. Securely screw the rinsing unit and the retaining plate onto the housing upper part.
3. Connect the hose for the water supply to the rinsing unit and to the water supply.
4. Push the rinse hose onto the rinse connection of the separation unit.
5. Shorten the rinse hose to the required length and connect it to the rinsing unit.
6. Connect the waste water hose to the overflow connection piece and to the waste outlet.
7. Connect the voltage supply of the rinsing unit at the suction unit.

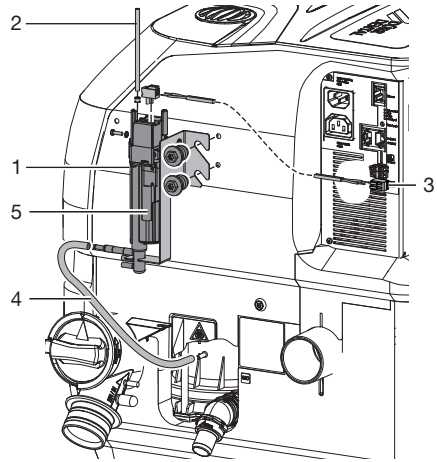

- 1 Rinsing unit
- 2 Water connection
- 3 Voltage supply for the rinsing unit
- 4 Rinsing hose
- 5 Overflow connection piece

## 8.4 Network connection

### Purpose of the network connection

The network connection is used to exchange information or control signals between the unit and a software installed on a computer, in order to, e. g.:

- Display parameters
  - Select operating modes
  - Indicate messages and error situations
  - Change unit settings
  - Activate test functions
  - Transmit data for archiving
  - Provide documents concerning the units
1. Plug in the network cable at the network connection on the unit (optional when using monitoring software).
  2. Plug in the network cable at the network socket.

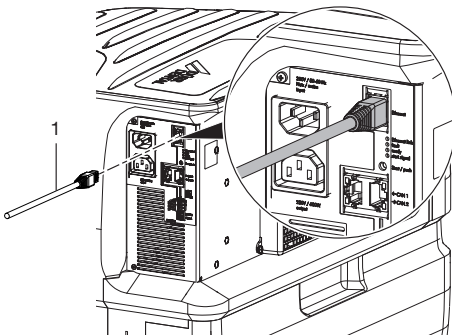

1 Network cable

## 8.5 CAN bus

### Purpose of the CAN bus connection

In a grouping of up to three devices, the CAN bus is used to enable mutual controlling and information exchange between the devices.

1. Connect the network cable between the devices at the CAN bus.

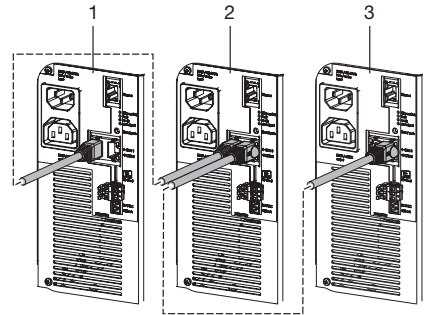

- 1 Main unit
- 2 Auxiliary unit 1
- 3 Auxiliary unit 2

## 8.6 Electrical connections



### WARNING

#### Electric shock

- › The device may only be connected to a supply system with a earthed power outlet.

1. Fasten the plug socket to the control line and connect to the device.



In a grouping of devices connect the control cable to the main unit.

2. Connect the mains cable to the unit and to the power outlet.

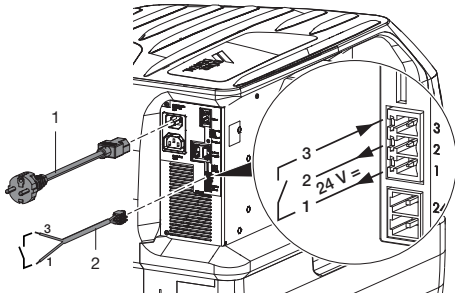

- 1 Mains cable with socket and country-specific mains plug
- 2 Control line

## 8.7 PCB (main board) electrical connections

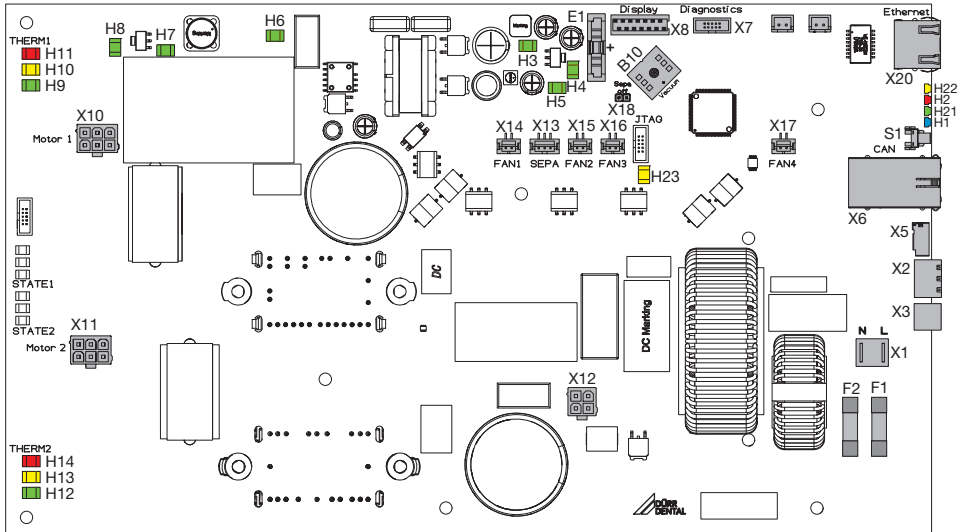

- X1 Supply voltage 230 V
- X2 Control voltage output, 24 V DC, control voltage input
- X3 Voltage supply for the rinsing unit, 24 V DC
- X5 SD card holder (for Micro SD)
- X6 CAN bus
- X7 Service interface
- X8 Connection for the display
- X10 Supply voltage for suction motor 1
- X11 Supply voltage for suction motor 2
- X12 Separation motor supply voltage (VS only)
- X13 Separation motor RPM monitor (VS only)
- X14 Fan connection for housing fan
- X15 Motor control fan connection 1
- X16 Motor control fan connection 2
- X17 Connection for cooling air fan (optional)
- X18 Jumper (V = closed, VS = open)
- X20 Network connection
- F1 Mains fuse T10.0AH
- F2 Mains fuse T10.0AH
- H1 Blue LED – start signal
- H2 Red LED – fault
- H3 Green LED – voltage supply +24 V
- H4 Green LED – voltage supply +3.3 V
- H5 Green LED – voltage supply +5 V

- H6 Green LED – HV voltage supply +15 V
- H7 Green LED – HV voltage supply +5V
- H8 Green LED – HV voltage supply +3.3 V
- H9 Green LED – temperature indicator for radial blower 1, temperature OK
- H10 Yellow LED – line to radial blower 1, short circuit or open circuit
- H11 Red LED – temperature indicator for radial blower 1, temperature too high
- H12 Green LED – temperature indicator for radial blower 2, temperature OK
- H13 Yellow LED – line to radial blower 2, short circuit or open circuit
- H14 Red LED – temperature indicator for radial blower 2, temperature too high
- H21 Green LED – ready for operation
- H22 Orange LED – network
- S1 Start button
- B10 Vacuum sensor
- E1 Battery (CR2032 button cell)

## 8.8 Testing suction power after installation

### Measure negative pressure

The following procedure is recommended for measuring the maximum negative pressure of the suction system for comparison with the performance curve:

1. Select the operating mode "Boost"+
2. Lift a suction hose off a treatment unit and connect a pressure gauge (relative pressure). The connection adapter to the pressure gauge must be leak tight.
3. Read the displayed negative pressure and compare it against the performance curve.

### Measure volume flow

To ensure that all particles and liquids sucked in are reliably removed, 300 - 350 l/min must be extracted at the suction cannula.

The volume flow can be measured with a suction flow meter, see "3.2 Optional items".

See also the installation and operating instructions for the measuring device.

1. Check the volume flow at the large suction hose on the treatment unit. Simultaneously lift the large suction hose depending on the maximum number of users on the treatment units.

If the volume flow is lower, the following causes may be present in the suction unit:

- Diameter of the pipe system is too small or unfavourable pipe construction
- Hose cross-sections are too small (instrument hose or hoses in the treatment unit)
- Dirty coarse/fine filter
- Hoses clogged
- Suction unit underpowered or defective

## 9 Commissioning



In many countries technical medical products and electrical devices are subject to regular checks at set intervals. The owner must be instructed accordingly.



### NOTICE

#### Interference caused by larger particles such as pieces of tooth or fillings

- › Do not operate the unit without a coarse filter

1. Check that the coarse filters are installed in the suction system (e.g. in the spittoon).
2. Turn on the unit power switch or the main surgery switch.
3. Carry out a function check of the device.
4. Check all connections for leak tightness.
5. Carry out an electrical safety check in accordance with applicable regulations (e.g. regulations concerning set up, operation and application of medical devices) and record the results as appropriate, e.g. in the technical log book.
6. Carry out and document the instruction and handover for the unit.



A sample handover report is included in the attachment.

### 9.1 Setup wizard

A setup wizard is displayed on the touch screen when the device is started for the first time or after a firmware update. To ensure trouble-free operation, please follow the instructions displayed in the setup wizard.

### 9.2 Settings on the touch screen

In the Settings screen you can query information and adjust settings.

To access the individual menu items, tap the relevant button. If there are multiple pages, the arrow buttons are used to scroll through the pages.

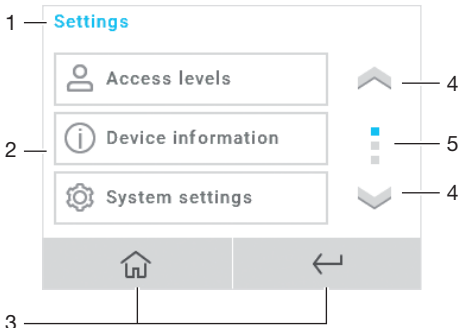

- 1 Title bar / submenus
- 2 Content area
- 3 Navigation buttons
- 4 Scroll button
- 5 Page indicator

**Changing to the Administrator user level:**

In the display screen, use the **Settings** button to switch to the menu screen. Use the **Access Level** button to switch to the selection for **User**, **Administrator** and **Service Technician [PIN]**. Then tap **Administrator** and confirm. Afterwards use the **Main Menu** button to go back.

**Selecting the operating mode**

Depending on the installation, the operating mode (suction power) of the device can be adjusted. Before changing the operating type, the suction power should be checked at the canulas.

The operating mode can be set in the display screen by tapping the **Eco**, **Balanced**, **Boost** or **Boost+** buttons. The selected operating mode is highlighted with a different colour.

**Deactivating/activating Boost+**

To deactivate/activate the Boost+ function, switch from the display screen to the menu screen with the **Settings** button. Then use the **Parameters** and **Operating mode** buttons to switch to the submenu. The function can now be activated or deactivated via the **Boost+** slider. If the function is active then the slider is shown in blue. This setting can be adjusted from the user level **Administrator** or higher.

 When operating devices as a group, set **Boost+** on the main unit.

**Adjust Tyscor Tandem group**

If several Tyscor suction units are operated in a group, one of the suction units must be defined

as the **main unit**. Each additional suction unit is then defined as **auxiliary unit 1** or **auxiliary unit 2**.

 On delivery, each device is preconfigured as a **main unit**.

Requirements:

- ✓ The suction units must be connected to each other via CAN bus.
- ✓ You need to be logged in as an **Administrator** on the touchscreen.

**Setting up the group settings:**

1. Use the **Settings** button to switch from the display screen to the menu screen.
2. Use the **Parameters** button to switch to **Cluster Settings**.
3. In the selection list, select whether the device is a **main unit** unit or an **auxiliary unit**.

**Control strategy in group operation**

If required, you can change the control strategy of the device or device group.

**Setting up the control strategy:**

1. Use the **Settings** button to switch from the display screen to the menu screen.
2. Use the **Parameters** button to go to **Control strategy options**.
3. In the selection list, select the desired control strategy of **Demand-based Mode** or **Parallel Mode**

 In **Parallel Mode**, increased power consumption and increased wear are to be expected.

**Adjust Tyscor Tandem Flex group**

In order to be able to operate the Tyscor suction unit in combination with a side channel suction unit, it is necessary to select the control strategy **Tyscor Tandem Flex** on the Tyscor suction unit.

Requirements:

- ✓ You need to be logged in as an **Administrator** on the touchscreen.

**Setting up the control strategy:**

1. Use the **Settings** button to switch from the display screen to the menu screen.

2. Use the *Parameters* button to go to *Control strategy options*.
3. Select the control strategy *Tyscor Tandem Flex* and save.



In this operating mode it is only possible to select the modes *Balanced* and *Boost*.

### Setting the afterrun delay time

Depending on the installation, the lag time of the device can be adjusted. The lag time can only be adjusted from the user level *Administrator* or higher.



When operating devices as a group, always adjust the lag time on the main unit.

#### **Adjusting the lag time:**

To adjust the lag time, switch from the display screen to the menu screen via the *Settings* button. Then use the *Parameters* and *Lag Time* buttons to adjust the time. Tap the *Save* button to save the time.

### Quick Start

Depending on the installation, the startup time of the device can be adjusted. The startup time can be adjusted from the user level *Administrator* or higher.



When operating devices as a group, set up the Quick Start function on the main unit.

#### **Activating Quick Start:**

To activate the Quick Start function, switch from the display screen to the menu screen by tapping the *Settings* button. Then switch to the submenu via the buttons *Parameters* and *Start/Stop*. The function can now be enabled or disabled via the *Quick Start* slider. If the function is active then the slider is shown in blue.

### Eco Stop

The Eco Stop function can be set to either a short time (enabled) or long time (disabled). This setting can be adjusted from the user level *Administrator* or higher.



When operating devices as a group, set up the Eco Stop function on the main unit.

#### **Enabling the Eco Stop:**

To activate the Eco Stop function, switch from the display screen to the menu screen by tapping the *Settings* button. Then switch to the submenu via the buttons *Parameters* and *Start/Stop*. The function can now be enabled or disabled via the *Eco Stop* slider. If the function is active then the slider is shown in blue.

### Exhaust air filter

If an exhaust air filter is used, this will need to be set up in the controller. This is the only way to ensure that a corresponding maintenance message is displayed at the right time.

#### **Settings for the exhaust air filter:**

To activate the maintenance counter for the exhaust air filter, switch from the display screen to the menu screen by tapping the *Settings* button. Then use the *Parameters* and *Exhaust Air Filter* buttons to switch to the selection list. In the list, select whether or not an exhaust air filter is fitted.

### Emergency mode

In emergency mode the device or group of devices can continue to be operated even if one of the device components is defective. Once the device component has been repaired, emergency mode will need to be reset. This can be done from user level *Administrator* or higher.

#### **Resetting emergency mode:**

To reset emergency mode, switch from the display screen to the menu screen with the *Settings* button. Then use the *Service* and *Emergency Mode* buttons to switch to the submenu. Use the button to reset emergency mode.

### Device components

In the *Device Components* menu you can deactivate one or possibly both radial blowers for maintenance purposes. The menu is available beginning in the *Administrator* user level.



Both of the radial blowers must be activated in normal operation.

#### **Deactivating/activating radial blower(s):**

To deactivate/activate radial blowers, switch from the display screen to the menu screen with the *Settings* button. Then use the *Service* and *Device Components* buttons to switch to the submenu. The desired motor can be deactivated/activated via the sliders for the top motor and bottom motor. If the motor is active then the slider is shown in blue.

During operation, the status of the motors is displayed in colour in the **Device Components** sub-menu. A green text shows that the motor is running. A red text shows that the motor has a fault.



Status changes are only displayed after calling up the **Device Components** sub-menu.

### 9.3 Monitoring the unit via the network

If the device is connected to the VistaSoft Monitor monitoring software via the local practice network, the software displays the device's messages, current status and upcoming maintenance.

The information can be viewed on the computer in the practice or via the cloud.

For further information, see VistaSoft Monitor handbook:



<http://qr.duerdental.com/2110300001>

The following requirements must be met in order to monitor the unit on the computer:

- Unit connected to the network
- Current monitoring software installed on the computer

### Combining devices safely

- The overall safety of the unit and its main performance features are independent of the network. The device is designed for operation independent of a network. However, some of the functions are not available in this case.
- Incorrect manual configuration can lead to significant network problems. The expert knowledge of a network administrator is required for configuration.
- The data connection utilises part of the bandwidth of the network. Interactions with other medical devices cannot be completely ruled out. Apply the IEC 80001-1 standard for risk assessment.
- The device is not suitable for direct connection to the public Internet.
- Protect the network with antivirus and firewall tools.
- Only allow authorised users to access the devices.
- Only allow authorised users to access the device network.
- Block access to the device network via the guest WiFi.
- Only download firmware updates from recognised, secure sources, e.g. directly from the manufacturer's website.

### Network configuration

Various options are available for network configuration:

- ✓ Automatic configuration via DHCP (recommended).
  - ✓ Automatic configuration via Auto-IP for direct connection of unit and computer.
  - ✓ Manual configuration.
1. Configure the network settings of the unit using the software or, if available, the touch screen.
  2. Check the firewall and release the ports, if applicable.

### Network protocols and ports

| Port                    | Purpose                            | Service     |
|-------------------------|------------------------------------|-------------|
| 45123 UDP,<br>45124 UDP | Unit recognition and configuration |             |
| 1900 UDP                | Service indicator                  | SSDP / UPnP |
| 502 TCP                 | Device data                        |             |

---

| Port                  | Purpose        | Service     |
|-----------------------|----------------|-------------|
| 514 <sup>1)</sup> UDP | Event log data | Syslog      |
| 22 TCP, 23 TCP        | Diagnosis      | Telnet, SSH |
| 123 UDP               | Time           | NTP         |

1) The port may vary depending on the configuration.

---

## Usage

 When using prophylaxis powders, water-soluble Lunos Prophylaxis Powders are recommended in order to protect the suction systems (Dürr Dental).

### 10 Disinfection and cleaning

The following tasks are required for the disinfection and cleaning of the suction system:

|                         |   |
|-------------------------|---|
| "10.1 Suctioning water" | After every treatment   |
| "10.2 Disinfection"     | Daily in the evening after the end of treatment,<br>With increased workloads, before the midday break and after the end of treatment                      |
| "10.3 Cleaning"         | Allow to act for at least 2 x per week before the start of treatment or during the midday break<br>Alternatively, 5 x per week, with short reaction times |



#### NOTICE

##### Device malfunction or damage cause by agents not approved by Dürr Dental

The use of cleaning agents and disinfectants not approved by Dürr Dental can cause device malfunctions and or damage to the device.

- Use only cleaning agents and disinfectants approved by Dürr Dental (Orotol plus, Orotol plus pH 7, MD 555 cleaner, MD 555 cleaner organic, Orotol ultra). Only these agents were tested for use in Dürr Dental suction systems.



#### Please note:

Damage caused by the use of agents not approved by Dürr Dental may cause warranty claims to become void.



Comply with the instructions for use of the cleaning agent and disinfectant.



#### Value retention with suitable servicing

Orotol plus and MD 555 cleaner are tested and approved by Dürr Dental. The products are compatible with the materials of the suction unit and provide thorough cleaning and disinfection. Deposits and biofilms are reliably removed – for lasting high performance and a long service life of your devices.

*Image (example): Dürr Dental VS 300 S after correct servicing according to operating instructions.*



#### Risks due to unsuitable products

The use of cleaning agents and disinfectants not tested and approved by Dürr Dental can have serious consequences. Foaming agents or aggressive substances can lead to malfunctioning, corrosion and permanent damage to the device.

*Image (example): Dürr Dental VS 300 S after cleaning with a non-approved foaming agent – with irreparable damage as a consequence.*

## 10.1 Suctioning water

After every treatment:

1. Suction up cold water (min. 0.5 litres) with the large and small suction hoses. Do this even if only the small suction hose was actually used during treatment.
-  Suction through the large suction hose causes a large amount of air to be drawn up, thereby considerably increasing the cleaning effect.

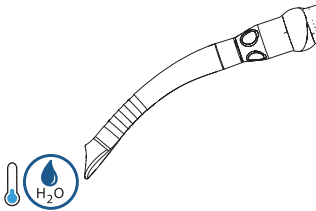



## 10.2 Disinfection

Disinfect and clean the suction system every evening after the end of treatment.

-  With increased workloads, clean and disinfect twice per day, e.g. before the mid-day break and after the end of treatment.

The following is required for the disinfection and cleaning of the suction system:

-  Non-foaming disinfectant/cleaning agent that is compatible with the materials
  - Orotol plus
  - Orotol plus pH 7

-  care system
  - e.g. OroCup

-  Disinfection and cleaning are described below with OroCup and Orotol plus.



Wear protective gloves.



Wear protective goggles.

1. To pre-clean, suction up 2 litres of water with the care system.



*Using the solution in the care system:*

1. Pour 2 sealing caps (40 ml) of Orotol plus into the OroCup.

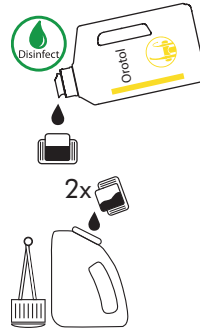

2. Fill the OroCup with 2 litres of cold water.

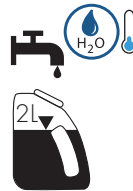

3. Close the lid of the care system.



4. Mix the solution.



Using the solution:

1. Attach suction hoses to the care system and suction up 1 litre of solution.

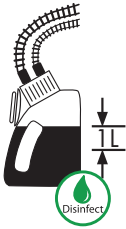

2. Pour the remaining solution into the spittoon.

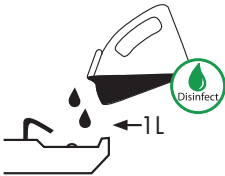

3. Allow to work for a minimum of one hour or leave overnight.
4. When placing the system back into operation, suction up 2 litres of water.



The instructions are also available as a video:



### 10.3 Cleaning

Clean the suction system regularly:

- Allow to act for at least 2 x per week in the morning before the start of treatment or during the midday break, reaction time 30–120 minutes
- Alternatively: 5 x per week before the start of treatment, reaction time 5–15 minutes

The following is required for cleaning the suction system:



Special non-foaming detergent for suction systems that is compatible with the materials

- MD 555 cleaner
- MD 555 cleaner organic



care system  
- e.g. OroCup



Cleaning is described below with OroCup and MD 555 cleaner.



Wear protective gloves.



Wear protective goggles.

1. To pre-clean, suction up 2 litres of water with the care system.



2. Use the solution in the care system.

Pour 5 caps (100 ml) of MD 555 cleaner into the care system.

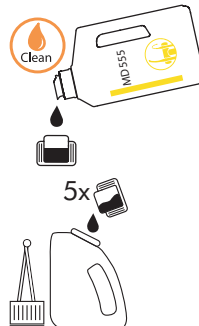

3. Fill the OroCup with 2 litres of cold water.

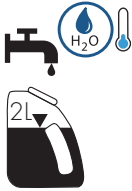

4. Close the lid of the care system.



5. Mix the solution.



6. Attach suction hoses to the care system and suction up one litre of solution.



7. Pour the remaining solution into the spittoon.



8. Allow the solution time to act.  
For 2 x per week: 30–120 minutes  
For 5 x per week: 5–15 minutes

9. Suction up 2 litres of water after the reaction time has elapsed.







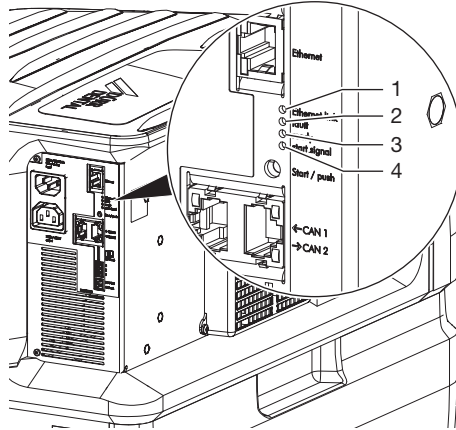

The instructions are also available as a video:



## 11 LEDs



- |   |                            |  |
|---|----------------------------|--|
| 1 | Network                    |  <p>ORANGE display is illuminated<br/>The machine is connected to the network.</p>  |
| 2 | Error                      |  <p>Red display flashes<br/>– Fault/failure of a radial blower</p>  <p>RED LED illuminates<br/>– Failure of both radial blowers<br/>or<br/>– Failure of separation (VS only)</p>   |
| 3 | Operation                  |  <p><b>Ready for operation</b><br/>Green LED lights up</p>  <p><b>EcoStop</b><br/>Green LED flashes<br/>The unit has been switched off by the EcoStop function. To switch it on, lift a suction hose up out of the hose manifold or briefly disconnect the power supply from the unit.</p> |
| 4 | Hose manifold start signal |  <p>BLUE LED illuminates<br/>Manifold signal active and machine running.</p>  |

## 12 Operating the touch screen

The selected operating mode and the current negative pressure are displayed on the Main Menu of the main unit. The operating mode can be changed by tapping one of the operating modes.

The **Next** button can be used to scroll to the next page, where the power consumption and temperature of the electronics are displayed.

The power consumption and temperature of the electronics are displayed on the Main Menu of the auxiliary unit.

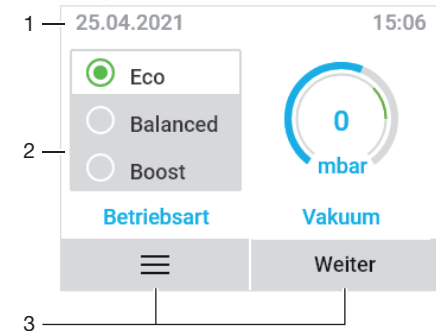



1 Context range (e.g. date, time)

2 Content area

3 Navigation buttons

The buttons at the bottom edge of the screen can be used to switch between the different menus.

 Switches to the menu **Settings**

**Next**  Switches between the two start screens (only when a device is configured as the "main unit")

 Switches to the start screen

 Switches to the next higher menu level

### 12.1 Querying messages

Any incidents that occur in the unit are shown in the Messages screen. The messages can be confirmed by tapping the navigation button. The messages are then displayed in the context area of the Home screen until the incident has been remedied.

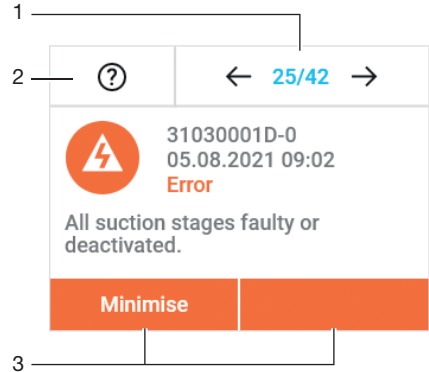

1 Scrolling between messages

2 Detailed information about the message

3 Navigation buttons

#### Severity of the messages:

 Information

 Note  
Important information about the device

 Notice  
Operation of the device restricted

 Fault  
Operation of the device interrupted

## 13 Maintenance

 All maintenance work must be performed by a qualified expert or by one of our Service Technicians.

| Maintenance interval | User maintenance work   |
|----------------------|---|
| Every 3 months       | › Check the filter at the device suction connection and clean if necessary. |

| Maintenance interval   | Maintenance work by service technician   |
|--|--|
| Annually   | › Replace the waste water valve.<br>› Check the nonreturn valves upstream of the radial blowers for correct operation and replace as required. |
| Every 1-2 years or when prompted if the maintenance counter is activated | › Replace the exhaust air filter (where fitted).   |

 Note maintenance information on the touchscreen and, if applicable, in VistaSoft Monitor.



### WARNING

#### Infection due to contaminated unit

- › Clean and disinfect the suction before working on the unit.
- › Wear protective equipment when working (e. g. impermeable gloves, protective goggles and mouth and nose protection).



Prior to working on the unit or in case of danger, disconnect it from the mains.

### 13.1 Wear parts and replacement parts

The following wear parts must be replaced at regular intervals:

|  |              |
|--|--------------|
| Nonreturn valve (pack of 3) . . . . .          | 7128-100-03E |
| Backflow preventer valve (pack of 2) . . . . . | 7188100082   |

 Information about replacement parts can be found on the website portal for specialist dealers under:  
[www.duerrdental.net](http://www.duerrdental.net)

### 13.2 Clean the filter at the device suction connection.

Clean the filter at the suction connection every 3 months.



#### WARNING

#### Infection due to contaminated unit

- Wear protective equipment when working (e. g. impermeable gloves, protective goggles and mouth and nose protection).

1. Loosen the filter at the suction connection by twisting it half a turn anti-clockwise.

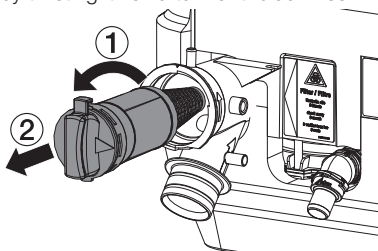

2. Clean the filter.

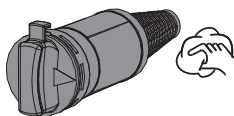

3. Push the filter with the opening facing upwards into the suction connection at the separation housing.
4. Screw in the protective filter clockwise as far as it will go.

### 13.3 Confirm maintenance

The maintenance interval can be reset on the touchscreen if maintenance has been carried out.

Requirements:

- ✓ Logged in as an Administrator on the touchscreen

1. Touch the touchscreen .
2. Touch **Maintenance**.
3. Select the maintenance task that was performed.
4. Touch **Maintenance Performed**.

### 13.4 Intensive cleaning

Intensive cleaning can be carried out during the self-clean process of suction systems that are heavily contaminated with biofilms or if the suction power is greatly reduced.

Carry out this intensive cleaning at least twice a week.

Exposure time: 1 – 2 hours

The following is required for intensive cleaning of the suction system:



Special non-foaming detergent for suction systems that is compatible with the materials

- MD 555 cleaner
- MD 555 cleaner organic



care system

- e.g. OroCup



Cleaning is described below with OroCup and MD 555 cleaner.



Wear protective gloves.



Wear protective goggles.

1. To pre-clean, suction up 2 litres of water with the care system.



2. Use the solution in the care system. Pour 10 caps (200 ml) of MD 555 cleaner into the care system.

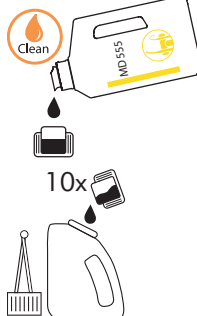

3. Fill the OroCup with 2 litres of cold water.

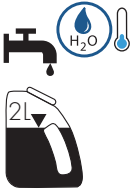

4. Close the lid of the care system.



5. Mix the solution.



6. Attach suction hoses to the care system and suction up one litre of solution.



7. Pour the remaining solution into the spittoon.



8. Allow the solution to act for 1 – 2 hours.

9. Suction up 2 litres of water after the reaction time has elapsed.



# ? Troubleshooting

## 14 Tips for operators and service technicians



Any repairs exceeding routine maintenance may only be carried out by qualified personnel or our service.



**WARNING**

**Infection due to contaminated unit**

- › Clean and disinfect the suction before working on the unit.
- › Wear protective equipment when working (e. g. impermeable gloves, protective goggles and mouth and nose protection).



Prior to working on the unit or in case of danger, disconnect it from the mains.



**WARNING**

**Electric shock due to capacitor discharge**

- › Wait for the discharge time.
- › Watch for the LEDs going out.

### 14.1 General faults

| Error  | Possible cause                          | Remedy   |
|--|---|--|
| <b>Device does not start</b>                                     | No mains voltage                        | <ul style="list-style-type: none"> <li>› Check the mains supply voltage. *</li> <li>› Check the fuses and replace if necessary. *</li> </ul>   |
|  | Undervoltage                            | <ul style="list-style-type: none"> <li>› Measure the supply voltage; call an electrician if necessary. *</li> </ul>  |
|  | Control electronics defective           | <ul style="list-style-type: none"> <li>› Replace the electronics. *</li> </ul>   |
| <b>The unit has been switched off, the green LED is flashing</b> | The EcoStop function has been activated | <ul style="list-style-type: none"> <li>› Lift up a suction hose from the hose manifold.</li> <li>› Briefly disconnect the power supply from the unit.</li> <li>› Check the switch in the hose manifold and replace as required. *</li> </ul> |

| Error  | Possible cause   | Remedy  |
|--|--|---|
| <b>Water leaking from the exhaust air connection</b> | Membrane valve defective   | › Check the membrane valve at the waste water connection and if necessary clean or replace.         |
|  | Foam in turbine due to use of incorrect cleaning and disinfectant agents | › Use non-foaming cleaning and disinfectant agents.   |
|  | Build-up of condensate in the exhaust air line                           | › Check the pipe system; avoid over-cooling. *  |
| <b>Suction performance too low</b>                   | Filter at the suction connection clogged                                 | › Clean the filter at the device suction connection.  |
|  | Leak in the suction pipe   | › Check and, if necessary, establish leak-tightness of the suction pipe and connections. *          |
|  | Soiling in the suction pipe  | › Check the pipe system and clean it as required. *   |
|  | Soiling in the separation stage  | › Check the separation stage and clean it as required. *  |
|  | Membrane valve defective   | › Check the membrane valve at the waste water connection and if necessary clean or replace.         |
|  | One radial blower defective  | › Replace the radial blower. *  |
| <b>No suction power</b>                              | Radial blower defective  | › Activate emergency mode by confirming the alarm message.  |
|  |  | › Replace radial blower. *  |
|  | Controller defective   | › Replace the controller. *   |
|  | Separation system defective  | › Check the separation system and clean or replace it as required. *                                |
|  | Main unit defective in group   | › Take the defective main unit out of operation and reconfigure an auxiliary unit as the main unit. |
| <b>Water not being pumped away</b>                   | Separation system defective  | › Replace separation system. *  |
| <b>Nothing shown on the display</b>                  | Cable defective or not connected   | › Check the cable connection and replace the cable if necessary. *                                  |
|  | Display defective  | › Replace the display. *  |

| Error                                      | Possible cause         | Remedy   |
|--|------------------------|--|
| <b>Display does not respond to touches</b> | Display not calibrated | <ul style="list-style-type: none"> <li>› Calibrate the display.</li> <li>– Disconnect and reconnect the mains plug. Within 8 seconds of the device being started, start the calibration process with a long press (5 s) on the display. Follow the instructions on the display.</li> </ul> |
|  | Display defective      | <ul style="list-style-type: none"> <li>› Replace the display. *</li> </ul>   |

\* Only to be done by service technicians.

## 14.2 Fault with Tyscor Tandem Flex

| Error  | Possible cause  | Remedy   |
|--|---|--|
| <b>No suction power</b><br>No error message on Tyscor touchscreen.<br>Error message on VistaSoft Monitor may appear if side channel suction machine is connected to Connect Box. | No mains voltage  | > Check the mains voltage. *<br>> Check the fuses and replace if necessary. *  |
|  | Motor circuit breaker has tripped   | > Switch motor circuit breaker back on. *  |
| <b>Low suction performance</b><br>Error message on the touchscreen of the Tyscor and in VistaSoft Monitor (if available).  | Side channel suction unit does not generate sufficient negative pressure, but the motor protection switch in the control box does not trip. | > Repair or replace side channel suction unit.*<br>> Change operation to Tyscor, see "Emergency mode: Change to Tyscor". |
|  | Tyscor suction unit defective.  | > Repair or replace Tyscor suction unit.*  |

\* Only to be done by service technicians.

 If the suction power is greatly reduced but there is no error message on the Tyscor suction unit, remove the suction hose from the hose holder for longer than 20 seconds. In this way, the control unit recognizes the failure of the side channel suction unit and the error message is triggered.

### Emergency mode: Change to Tyscor

The operation of Tyscor Tandem Flex is set on the control line switch:



**0** Tyscor Tandem Flex deactivated.  
The start signal is only sent to the Tyscor suction unit.

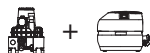

**I** Tyscor Tandem Flex activated.  
The start signal is sent to both suction units. The Tyscor monitors the vacuum in the suction line and switches on automatically if necessary.

If the motor protection in the control box of the side channel suction unit has tripped, Tyscor no longer receives a start signal and therefore no longer switches on. In this case, the emergency mode must be activated.

By activating emergency operation, only the Tyscor suction unit receives a start signal.

 In emergency mode, only a reduced output is available.

1. Check the control box of the side channel suction unit to see if the motor protection switch has tripped. If not, switch off the control box.
2. Close the ball valve to the side channel suction unit.
3. Set the switch in the control line to "0" .
4. Confirm error message at the Tyscor.  
The control strategy of the Tyscor suction unit is switched to the standard mode.

5. If no error message is displayed on the Tyscor, manually switch to standard mode on the touchscreen under *Settings > Parameters > Control Strategy Options*.

## 14.3 Error messages



Error messages are displayed on the touch screen. If there is a network connection, the messages can be forwarded to the monitoring software. If the device is not connected to the network, the messages can be read via a terminal client (e. g. PuTTY).

| Error   | Possible cause   | Remedy  |
|---|--|---|
| <b>Maintenance required. Clean filter at device suction connection.</b> | Service due  | <ul style="list-style-type: none"> <li>➤ Clean the filter at the device suction connection.</li> <li>➤ Reset the maintenance in the menu.</li> </ul>  |
| <b>Maintenance required. Check waste valve.</b>                         | Service due  | <ul style="list-style-type: none"> <li>➤ Check the waste valve. *</li> <li>➤ Reset the maintenance in the menu. *</li> </ul>  |
| <b>Maintenance required. Replace exhaust air filter.</b>                | Service due  | <ul style="list-style-type: none"> <li>➤ Replace the exhaust air filter *</li> <li>➤ Reset the maintenance in the menu. *</li> </ul>  |
| <b>Severe fault detected. Confirm to enter emergency mode.</b>          | A radial blower is defective                                 | <ul style="list-style-type: none"> <li>➤ Confirm to enter emergency mode.</li> <li>➤ Immediately repair or replace the radial blower. *</li> <li>➤ Reset emergency mode in the menu. *</li> </ul>   |
| <b>Severe fault detected. Call service.</b>                             | A radial blower is defective.<br>Emergency mode unavailable. | <ul style="list-style-type: none"> <li>➤ Immediately repair or replace the radial blower. *</li> </ul>  |
| <b>This device is running in emergency mode. Call service.</b>          | Device is running in emergency mode                          | <ul style="list-style-type: none"> <li>➤ Immediately repair or replace the radial blower. *</li> <li>➤ Reset emergency mode in the menu. *</li> </ul>   |
| <b>An Aux device has a severe failure. Confirm at affected device.</b>  | A radial blower on an auxiliary unit is defective            | <ul style="list-style-type: none"> <li>➤ Confirm to enter emergency mode.</li> <li>➤ Immediately repair or replace the radial blower. *</li> <li>➤ Reset emergency mode in the menu. *</li> </ul>   |
| <b>An Aux device is running in emergency mode. Call service.</b>        | An auxiliary unit is running in emergency mode               | <ul style="list-style-type: none"> <li>➤ Immediately repair or replace the radial blower. *</li> <li>➤ Reset emergency mode in the menu. *</li> </ul>   |
| <b>Tyscor Tandem Flex operation: Side channel blower defective</b>      | Side channel fan defective                                   | <ul style="list-style-type: none"> <li>➤ Deactivate side channel fan on the control box.</li> <li>➤ Close the pipes to the side channel fan at the ball valve.</li> <li>➤ Switch the deposit signal to the Tyscor suction unit.</li> <li>➤ Confirm error message on the display.</li> </ul> |
| <b>Driver overcurrent TRIP</b>  | Radial blower motor defective                                | <ul style="list-style-type: none"> <li>➤ Replace the radial blower. *</li> </ul>  |

| <b>Error</b>                                  | <b>Possible cause</b>   | <b>Remedy</b>  |
|---|---|--|
| <b>Speed of Sepa is low</b>                   | Motor defective   | › Replace the separation stage. *  |
|   | Hall sensor PCB (main board) defective                                    | › Replace the Hall sensor PCB (main board), check the magnets in the Sepa fan. * |
|   | Centrifuge soiled or damaged  | › Check the centrifuge and clean or replace if necessary. *                      |
| <b>Vacuum motor overheated</b>                | Radial blower motor defective   | › Replace the radial blower. *   |
| <b>DC bus overvoltage</b>                     | Control error   | › Replace the electronics. *   |
| <b>DC bus undervoltage</b>                    | Mains power supply fault  | › Check the mains connection and supply voltage. *                               |
|   | Machine was disconnected from the mains while running                     | › No action required.  |
|   | Control error   | › Replace the electronics. *   |
| <b>No Ready Signal from vacuum machine</b>    | Control error   | › Replace the electronics. *   |
| <b>Internal board communication disturbed</b> | Failed firmware update  | › Perform/repeat the firmware update. *  |
|   | Control error   | › Replace electronics. *   |
| <b>Unexpected re-initialization</b>           | Firmware error  | › Perform/repeat the firmware update. *  |
| <b>Short circuit to earth</b>                 | Radial blower motor defective   | › Replace radial blower. *   |
| <b>Vacuum motor sensor shorted</b>            | Radial blower motor defective   | › Replace radial blower. *   |
| <b>Vacuum motor sensor open circuit</b>       | Radial blower motor defective   | › Replace radial blower. *   |
|   | Motor cable not correctly connected to the control board                  | › Check the plug connection. *   |
| <b>Firmware mismatch</b>                      | Different firmware versions on the two processors after a firmware update | › Perform/repeat the firmware update. *  |
| <b>Speed Feedback Failure</b>                 | Motor speed detection defective   | › Replace radial blower. *   |
| <b>MC Lib failure</b>                         | Control error   | › Replace the electronics. *   |
| <b>CPU overheated</b>                         | Insufficient ventilation or poor set-up conditions                        | › Check the setup conditions, ensure adequate ventilation.                       |
|   | Fan in the foam housing soiled  | › Clean the fan and ventilation slots for supply and exhaust air. *              |
|   | Fan in foam housing defective   | › Replace the fan. *   |
|   | Control electronics defective   | › Replace electronics. *   |

| <b>Error</b>  | <b>Possible cause</b>                                   | <b>Remedy</b>   |
|---|---|---|
| <b>Power Pack overheated</b>  | Insufficient ventilation or poor set-up conditions      | › Check the setup conditions, ensure adequate ventilation.                    |
|   | Fan on the electronics housing soiled                   | › Remove the cover on the electronics housing, clean the fan and heat sink. * |
|   | Fan on electronics housing defective                    | › Replace the fan. *  |
|   | Control electronics defective                           | › Replace electronics. *  |
| <b>Eco Stop. Switch start signal off and on again to restart</b>      | Unit has been switched on unintentionally for too long. | › Check whether all suction hoses are correctly hung up.                      |
|   |   | › Briefly disconnect the unit from the mains.                                 |
|   |   | › Check whether a permanent start signal is present at the unit. *            |
|   |   | › Check the control cable. *  |
| <b>All devices failed or deactivated</b>                              | Radial blower defective                                 | › Replace the radial blower. *  |
|   | Radial blower deactivated                               | › Inform a Service Technician.  |
| <b>More than one main control unit detected. Wrong configuration!</b> | Configuration error. More than one main unit found      | › Make sure that only one device is configured as the main unit. *            |
| <b>No main control unit detected. Check system.</b>                   | No main unit found. Check the system.                   | › Configure one device as the main unit. *                                    |
| <b>Auxiliary unit has error.</b>                                      | Fault on auxiliary unit                                 | › Check the fault on the affected auxiliary unit *                            |

\* Only to be done by service technicians.

## 15 Transporting the unit



### WARNING

#### Infection due to contaminated unit

- › Disinfect the unit before transport.
- › Close all media connections.



Wear protective equipment to avoid any risk of infection (e.g. liquid-tight protective gloves, protective goggles, face mask).

1. Prior to disassembly, clean and disinfect the suction unit and the unit via aspiration of a suitable disinfectant approved by the manufacturer.
2. Disinfect a defective unit using a suitable surface disinfection agent.
3. Seal all connections with sealing caps.
4. Pack the unit securely in preparation for transport.

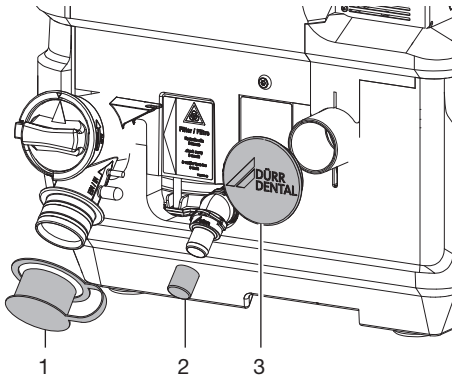

- 1 Suction connection sealing cap (order number 7130-100-19)
- 2 Waste water connection sealing cap (order number 9000-412-98)
- 3 Sealing cap (order number 900041298)

# Appendix

## 16 Menu structure

|              |                                 |                          |                       |          |                          |  |
|--------------|---------------------------------|--------------------------|-----------------------|----------|--------------------------|--|
| Setup wizard | <i>Language</i>                 |                          |                       |          |                          |  |
|              | <i>Operating mode</i>           |                          |                       |          |                          |  |
|              | <i>Exhaust air filter</i>       |                          |                       |          |                          |  |
|              | <i>Finished</i>                 |                          |                       |          |                          |  |
| Start screen | <i>Operating mode, vacuum</i>   |                          |                       |          |                          |  |
|              | <i>Performance, temperature</i> |                          |                       |          |                          |  |
|              | <i>Control strategy options</i> |                          |                       |          |                          |  |
| Settings     | Access levels                   | Operator                 |                       |          |                          |  |
|              |                                 | Administrator            |                       |          |                          |  |
|              |                                 | Service Technician [PIN] | XXXXXX                |          |                          |  |
|              | Device information              | Device data              | REF                   |          |                          |  |
|              |                                 |                          | SN                    |          |                          |  |
|              |                                 |                          | Firmware              |          |                          |  |
|              |                                 |                          | Upgrade               |          |                          |  |
|              |                                 |                          | Library version       |          |                          |  |
|              |                                 |                          | PCB serial number     |          |                          |  |
|              |                                 |                          | File                  |          |                          |  |
|              |                                 |                          | Device usage data     |          | Number of starts         |  |
|              |                                 |                          | System settings       | Language | German, English, . . . , |  |
|              |                                 |                          |                       |          | Date / time <sup>2</sup> |  |
|              | Automatic                       |                          |                       |          |                          |  |
|              | Date                            | DD MM YYYY               |                       |          |                          |  |
|              | Time                            | HH MM                    |                       |          |                          |  |
|              | Time zone                       | UTC                      |                       |          |                          |  |
|              | Network <sup>2</sup>            | DHCP                     |                       |          |                          |  |
|              |                                 | IP address               |                       |          |                          |  |
|              |                                 | Subnet mask              |                       |          |                          |  |
|              |                                 | Gateway                  |                       |          |                          |  |
|              |                                 | MAC                      |                       |          |                          |  |
|              | Factory settings <sup>1</sup>   |                          | Clear message history |          |                          |  |

|   |   |                           |                   |
|---|---|---------------------------|-------------------|
| Settings (continued)                        | Parameters <sup>2</sup>                     | Cluster settings          | Main unit         |
|   |   |                           | Auxiliary unit 1  |
|   |   |                           | Auxiliary unit 2  |
|   |   | Lag time <sup>3</sup>     | XX s              |
|   |   | Start / stop <sup>3</sup> | Quick Start       |
|   |   |                           | Eco Stop          |
|   | Exhaust air filter <sup>2</sup>             | Exhaust filter present    |                   |
|   |   | No exhaust air filter     |                   |
|   | Control strategy options <sup>3</sup>       | Adaptive operation        |                   |
|   |   | Parallel operation        |                   |
|   |   | Tyscor Tandem Flex        |                   |
|   | Operating mode <sup>3</sup>                 | Boost+                    |                   |
|   | Message history <sup>2</sup><br>maintenance | List of alarms            | Alarm information |
| Filter maintenance                          |   | Maintenance completed     |                   |
| Waste valve maintenance <sup>2</sup>        |   | Maintenance completed     |                   |
| Exhaust air filter maintenance <sup>2</sup> |   | Maintenance completed     |                   |
| Service <sup>2</sup>                        | Emergency mode                              | Reset                     |                   |
|   | Device components                           | Motor 0 (top)             |                   |
|   |   | Motor 1 (bottom)          |                   |
|   | Separation <sup>1</sup>                     |                           |                   |

<sup>1</sup> only as Service Technician

<sup>2</sup> only as Administrator

<sup>3</sup> only as Administrator and only on the main machine

## 17 Handover record

This document confirms that a qualified handover of the medical device has taken place and that appropriate instructions have been provided for it. This must be carried out by a qualified adviser for the medical device, who will instruct you in the proper handling and operation of the medical device.

| Product name | Order number (REF) | Serial number (SN) |
|--------------|--------------------|--------------------|
|              |                    |                    |
|              |                    |                    |
|              |                    |                    |
|              |                    |                    |

- Visual inspection of the packaging for any damage
- Unpacking the medical device and checking for damage
- Confirmation of the completeness of the delivery
- Instruction in the proper handling and operation of the medical device based on the operating instructions

**Notes:**

|  |
|--|
|  |
|  |

**Name of person receiving instruction:**                      **Signature:**

|  |  |
|--|--|
|  |  |
|  |  |
|  |  |
|  |  |

**Name and address of the qualified adviser for the medical device:**

|  |
|--|
|  |
|  |
|  |
|  |

**Date of handover:**    **Signature of the qualified adviser for the medical device:**

|  |  |
|--|--|
|  |  |
|--|--|

## 18 Country representatives

| Country  | Address   |
|--|---|
| UA<br><br>UA.TR.099 | <b>Уповноважений представник в Україні:</b><br>Приватне підприємство “Галіт”<br>вул. 15 квітня, 6Є, с. Байківці,<br>Тернопільський р-н,<br>47711, Україна<br>тел.: 0800 502 998;<br>+38 050 338 10 64<br><a href="http://www.galit.te.ua">www.galit.te.ua</a> ;<br>e-mail: <a href="mailto:office@galit.te.ua">office@galit.te.ua</a><br><br>Виробник: Дюрр Дентал ЕсЕ<br>Хьолфгхаймер Штрассе 17,<br>Д-74321 Бітігхайм-Біссінген,<br>Німеччина<br>email: <a href="mailto:info@duerrdental.com">info@duerrdental.com</a>                                  |
| GB   | <b>UK Responsible Person:</b><br>Duerr Dental (Products) UK Ltd.<br>14 Linnell Way<br>Telford Way Industrial Estate<br>Kettering, Northants NN 16 8PS   |
| CN   | 案人/生 企 : DÜRR DENTAL SE 德国迪珥 科股份公司<br>住所/生 地址 : Höpfigheimer Str. 17, 74321 Bietigheim-Bissingen, Germany<br>系方式:<br>: + 49 7142 705-0<br>箱 : <a href="mailto:info@duerrdental.com">info@duerrdental.com</a><br>网址 : <a href="http://www.duerrdental.com">www.duerrdental.com</a><br><br>代理人/售后服 位 : 迪珥医 器械(上海)有限公司<br>住所 : 上海市 宁区天山路 641 号 2 号楼 (20 幢) 303 室<br>系方式:<br>: + 86 21 6381 0270<br>真 : + 86 21 6381 0290<br>箱 : <a href="mailto:info@duerr.cn">info@duerr.cn</a><br>网址 : <a href="http://www.duerrdental.com">http://www.duerrdental.com</a> |
| CH<br>            | <b>Schweizer Bevollmächtiger:</b><br>DÜRR DENTAL SCHWEIZ AG<br>Grabenackerstraße 27<br>8156 Oberhasli<br>Switzerland  |
| AU<br>            | <b>DURR DENTAL OCEANIA PTY LTD</b><br>7/42 Sabre Drive<br>3207 Port Melbourne Victoria I Australia  |











**Hersteller / Manufacturer:**

DÜRR DENTAL SE  
Höfigheimer Str. 17  
74321 Bietigheim-Bissingen  
Germany  
Fon: +49 7142 705-0  
[www.duerrdental.com](http://www.duerrdental.com)  
[info@duerrdental.com](mailto:info@duerrdental.com)

